

**Bantayan Island Electric Cooperative, Inc.
(BANELCO)**

Balintawak, Bantigue, Cebu

Tel/Fax No.: (032) 460-9281; (032) 460-9112

Email address: banelcoonline@yahoo.com

BIDDING DOCUMENTS

BANELCO

ITB # 2024 – 04

**Lot 3: Supply, Delivery and Installation of
On-shore Cable Protection, Primary Metering,
Line Conversion and Extension**

TABLE OF CONTENTS

Glossary of Terms, Abbreviations, and Acronyms	2
Section I. Invitation to Bid	5
Section II. Instructions to Bidders.....	8
1. Scope of Bid	9
2. Funding Information	9
3. Bidding Requirements	9
4. Corrupt, Fraudulent, Collusive, Coercive, and Obstructive Practices	9
5. Eligible Bidders	9
6. Origin of Associated Goods	10
7. Subcontracts	10
8. Pre-Bid Conference	11
9. Clarification and Amendment of Bidding Documents	11
10. Documents Comprising the Bid: Eligibility and Technical Components	11
11. Documents Comprising the Bid: Financial Component	12
12. Alternative Bids	12
13. Bid Prices	12
14. Bid and Payment Currencies	12
15. Bid Security	12
16. Sealing and Marking of Bids	13
17. Deadline for Submission of Bids	13
18. Opening and Preliminary Examination of Bids	13
19. Detailed Evaluation and Comparison of Bids	14
20. Post Qualification	15
21. Notice of Award	16
22. Signing of the Contract	17
Section III. Bid Data Sheet.....	18
Section IV. General Conditions of Contract	21
Section V. Special Conditions of Contract.....	52
Section VI. Specifications, Drawings.....	55
Section VII. Scope of Work	73
Section VIII. Bidding Forms	75
Section IX. Checklist of Technical and Financial Documents.....	88

Glossary of Terms, Abbreviations, and Acronyms

ABC – Approved Budget for the Contract.

ARCC – Allowable Range of Contract Cost.

BAC – Bids and Awards Committee.

Bid – A signed offer or proposal to undertake a contract submitted by a bidder in response to and in consonance with the requirements of the bidding documents. Also referred to as *Proposal* and *Tender*. (2016 revised IRR, Section 5[c])

Bidder – Refers to a contractor, manufacturer, supplier, distributor and/or consultant who submits a bid in response to the requirements of the Bidding Documents. (2016 revised IRR, Section 5[d])

Bidding Documents – The documents issued by the Procuring Entity as the bases for bids, furnishing all information necessary for a prospective bidder to prepare a bid for the Goods, Infrastructure Projects, and/or Consulting Services required by the Procuring Entity. (2016 revised IRR, Section 5[e])

BIR – Bureau of Internal Revenue.

BSP – Bangko Sentral ng Pilipinas.

CDA – Cooperative Development Authority.

Consulting Services – Refer to services for Infrastructure Projects and other types of projects or activities of the GOP requiring adequate external technical and professional expertise that are beyond the capability and/or capacity of the GOP to undertake such as, but not limited to: (i) advisory and review services; (ii) pre-investment or feasibility studies; (iii) design; (iv) construction supervision; (v) management and related services; and (vi) other technical services or special studies. (2016 revised IRR, Section 5[i])

Contract – Refers to the agreement entered into between the Procuring Entity and the Supplier or Manufacturer or Distributor or Service Provider for procurement of Goods and Services; Contractor for Procurement of Infrastructure Projects; or Consultant or Consulting Firm for Procurement of Consulting Services; as the case may be, as recorded in the Contract Form signed by the parties, including all attachments and appendices thereto and all documents incorporated by reference therein.

Contractor – is a natural or juridical entity whose proposal was accepted by the Procuring Entity and to whom the Contract to execute the Work was awarded. Contractor as used in these Bidding Documents may likewise refer to a supplier, distributor, manufacturer, or consultant.

CPI – Consumer Price Index.

DOLE – Department of Labor and Employment.

DTI – Department of Trade and Industry.

Foreign-funded Procurement or Foreign-Assisted Project – Refers to procurement whose funding source is from a foreign government, foreign or international financing institution as specified in the Treaty or International or Executive Agreement. (2016 revised IRR, Section 5[b]).

GFI – Government Financial Institution.

GOCC – Government-owned and/or –controlled corporation.

Goods – Refer to all items, supplies, materials and general support services, except Consulting Services and Infrastructure Projects, which may be needed in the transaction of public businesses or in the pursuit of any government undertaking, project or activity, whether in the nature of equipment, furniture, stationery, materials for construction, or personal property of any kind, including non-personal or contractual services such as the repair and maintenance of equipment and furniture, as well as trucking, hauling, janitorial, security, and related or analogous services, as well as procurement of materials and supplies provided by the Procuring Entity for such services. The term “related” or “analogous services” shall include, but is not limited to, lease or purchase of office space, media advertisements, health maintenance services, and other services essential to the operation of the Procuring Entity. (2016 revised IRR, Section 5[r])

GOP – Government of the Philippines.

Infrastructure Projects – Include the construction, improvement, rehabilitation, demolition, repair, restoration or maintenance of roads and bridges, railways, airports, seaports, communication facilities, civil works components of information technology projects, irrigation, flood control and drainage, water supply, sanitation, sewerage and solid waste management systems, shore protection, energy/power and electrification facilities, national buildings, school buildings, hospital buildings, and other related construction projects of the government. Also referred to as *civil works or works*. (2016 revised IRR, Section 5[u])

LGUs – Local Government Units.

NFCC – Net Financial Contracting Capacity.

NGA – National Government Agency.

PCAB – Philippine Contractors Accreditation Board.

PhilGEPS - Philippine Government Electronic Procurement System.

Procurement Project – refers to a specific or identified procurement covering goods, infrastructure project or consulting services. A Procurement Project shall be described, detailed, and scheduled in the Project Procurement Management Plan prepared by the agency which shall be consolidated in the procuring entity's Annual Procurement Plan. (GPPB Circular No. 06-2019 dated 17 July 2019)

PSA – Philippine Statistics Authority.

SEC – Securities and Exchange Commission.

SLCC – Single Largest Completed Contract.

UN – United Nations.

Section I. Invitation to Bid



Bantayan Island Electric Cooperative, Inc. (BANELCO)
 Balintawak, Bantigue, Bantayan, Cebu
 Tel/Fax No.: (032) 460-9281; (032) 460-9112
 Email address: banelcoonline@yahoo.com
 Website: www.banelcobantayan.com

Invitation to Bid No. 2024-004

BANTAYAN ISLAND ELECTRIC COOPERATIVE, INC. through its Bids and Awards Committee (BAC), hereby invites all accredited suppliers and contractors to submit their respective bids for Supply of materials, tools, equipment and labor for the installation, test and commissioning of SUBMARINE CABLE and its protections in Moamboc Sulangan, Bantayan to Hilotongan, Bantayan, Cebu to be Funded by 2024 LFP-TEP Subsidy.

Lot Number	Particulars	PCAB License Requirement	ABC (PhP)	Price of Bid Documents	Project Duration
			inclusive of VAT	(non-refundable)	
Lot 1	Supply, Delivery Test & Commissioning of Submarine Power Cable (bundled 3 - core) 5600 meters, 15kv 60mm ² with 16-core optical fiber, Termination Kits and its Accessories Made in G10 Countries	None	59,656,844.59	PhP 50,000.00	180 CD
Lot 2	Submarine Cable Laying, Support & Installation of Offshore Cable Protections	Electrical or Offshore Engineering	30,803,321.08	PhP 25,000.00	180 CD
Lot 3	Supply, Delivery and Installation of On-shore Cable Protection, Primary Metering, Line Conversion and Extension	Electrical or Offshore Engineering	5,925,075.00	PhP 10,000.00	60 CD

ACTIVITIES	SCHEDULE
Advertisement/Posting of Invitation to Bid	November 15, 2024
Issuance and Availability of Bid Documents	November 18, 2024
Pre-Bid Conference	November 22, 2024 1:30PM
Deadline of Queries	November 29, 2024
Final Issuance of Supplemental Bid Bulletin	December 3, 2024
Deadline of Submission and Opening of Bids	December 6, 2024 10:00AM

Bidding will be conducted through open competitive bidding procedures using a non-discretionary “pass/fail” criterion as specified in the 2016 Revised Implementing Rules and Regulations (IRR) of Republic Act (RA) 9184 otherwise known as the “Government Procurement Reform Act”.

All Bids shall be opened and read in the presence of Bidders or their duly authorized representatives. Bidders shall be required to put up a Bid Security in the amount equivalent to 2% of the ABC. The Bid Security shall be in the form of cash or manager’s check and submitted together with their Bids.

Pre-Bid Conference shall be open to all interested parties; however, only those who have purchased the Bidding Documents may participate the discussion at said conference to be held at BANELCO Office, Bantigue, Bantayan, Cebu.

Only those bidders who have bought the bidding documents shall be allowed to participate the Submission and Opening of Bids.

The Pre-Bid Conference, Submission and Opening of Bids will be held via face-to-face at BANELCO Office, Bantigue, Bantayan, Cebu.

Interested bidders may download the bid documents from BANELCO website or maybe acquired further information from BANELCO Office at Cell Numbers 09311176126/ 09437012696, Landline 032-4609112, 032-4609281 or call 09232641889 and look for Ms. Maria Ruby Capundag or email at banelco.bac@gmail.com during office hours.

BANELCO reserves the right to accept or reject any bid, to annul the bidding process, and to reject all bids at any time prior to the awarding of contract, thereby without incurring any liability to the affected bidder or bidders.

(SGD) ENGR. RONALD D. ALOYAN

Chairman, BAC

Noted by:

(SGD) ENGR. LEE D. RIVERA

General Manager

Section II. Instructions to Bidders

1. Scope of Bid

2. The Procuring Entity, BANELCO wishes to receive Bids for the Supply, Delivery and Installation of On-shore Cable Protection, Primary Metering, Line Conversion and Extension.

The fund for this engagement shall be sourced from 2024 LFP-TEP (Locally Funded Project – Total Electrification Project) Subsidy.

3. Bidding Requirements

The Bidding for the Project shall be governed by all the provisions of RA No. 9184 and its 2016 revised IRR, including its Generic Procurement Manual and associated policies, rules and regulations as the primary source thereof, while the herein clauses shall serve as the secondary source thereof.

Any amendments made to the IRR and other GPPB issuances shall be applicable only to the ongoing posting, advertisement, or invitation to bid by the BAC through the issuance of a supplemental or bid bulletin.

The Bidder, by the act of submitting its Bid, shall be deemed to have inspected the site, determined the general characteristics of the contracted Works and the conditions for this Project, such as;

- (a) the location and the nature of the work;
- (b) climatic conditions;
- (c) transportation facilities;
- (d) nature and condition of the terrain, geological conditions at the site communication facilities, requirements, location and availability of construction aggregates and other materials, labor, water, electric power and access roads; and
- (e) other factors that may affect the cost, duration and execution or implementation of the contract, project, or work and examine all instructions, forms, terms, and project requirements in the Bidding Documents.

4. Corrupt, Fraudulent, Collusive, Coercive, and Obstructive Practices

The Procuring Entity, as well as the Bidders and Contractors, shall observe the highest standard of ethics during the procurement and execution of the contract. They or through an agent shall not engage in corrupt, fraudulent, collusive, coercive, and obstructive practices defined under Annex “I” of the 2016 revised IRR of RA No. 9184 or other integrity violations in competing for the Project.

5. Eligible Bidders

- 5.1. Only bids of bidders found to be legally, technically, and financially capable will be evaluated.
- 5.2. Only bidders which meet the eligibility criteria provided below shall be eligible to participate in this bidding.

- 5.3 Filipino Citizens/Sole Proprietorships; Partnerships or Corporations with at least Sixty Percent (60%) of the interest or outstanding capital stock belonging to citizens of the Philippines; Cooperatives duly registered with the Cooperative Development Authority (CDA); or Joint Ventures with at least sixty percent (60%) Filipino interest/ownership shall be eligible to participate in this Bidding.
- 5.4 The bidder must have completed a Single Largest Completed Contract (SLCC) that is similar to the Project for the last ten years. The SLCC: (a) must be equivalent to Fifty Percent (50%) of the Total ABC.
- 5.5 For the purpose of this bidding a similar contract or project shall mean contracts for Supply, Delivery and Installation of On-shore Cable Protection, Primary Metering, Line Conversion and Extension.
- 5.6 The bidder's Net Financial Contracting Capacity (NFCC) should be equal or more than the Total ABC.
- 5.7 Foreign ownership exceeding those allowed under the rules may participate pursuant to:
 - a) When a Treaty or International or Executive Agreement as provided in Section 4 of the RA No. 9184 and its 2016 revised IRR allow foreign bidders to participate;
 - b) Citizens, corporations, or associations of a country, included in the list issued by the GPPB, the laws or regulations of which grant reciprocal rights or privileges to citizens, corporations, or associations of the Philippines;
 - c) When the Goods sought to be procured are not available from local suppliers; or
 - d) When there is a need to prevent situations that defeat competition or restrain trade.
- 5.8 The Bidders shall comply with the eligibility criteria under Section 23.4.1 of the 2016 IRR of RA No. 9184.
- 5.9 Must have a valid PCAB License in Electrical or Offshore Engineering.

6. Origin of Associated Goods

Unless otherwise indicated in the **BDS**, there is no restriction on the origin of Goods other than those prohibited by a decision of the UN Security Council taken under Chapter VII of the Charter of the UN.

7. Subcontracts

- 7.1. The Procuring Entity has prescribed that Subcontracting is not allowed.

8. Pre-Bid Conference

- 8.1 Pre-bid conference shall be conducted via face-to-face on **November 22, 2024, 1:30 P.M.** at *BANELCO office, Balintawak Bantigue, Bantayan Cebu.*
- 8.2 The pre-bid conference shall: (a) discuss, among others, the eligibility requirements and the technical and financial components of the contract to be bid as stipulated in the Bidding Documents; and (b) clarify any provisions, requirements, and/or terms and conditions of the Bidding Documents and/or any other matter that the prospective bidders may raise.
- 8.3 Attendance of the bidders to the pre-bid conference is optional, except when otherwise stated in the Invitation to Bid.

9. Clarification and Amendment of Bidding Documents

Prospective bidders may request for clarification on and/or interpretation of any part of the Bidding Documents. Such requests must be in writing and received by the Procuring Entity, either at its given address or through electronic mail indicated in the **IB**, at least seven (7) calendar days before the deadline set for the submission and receipt of Bids.

10. Documents Comprising the Bid: Eligibility and Technical Components

- 10.1. The first envelope shall contain the eligibility and technical documents of the Bid as specified in **Section IX. Checklist of Technical and Financial Documents.**
- 10.2. If the eligibility requirements or statements, the bids, and all other documents for submission to the BAC are in foreign language other than English, it must be accompanied by a translation in English, which shall be authenticated by the appropriate Philippine foreign service establishment, post, or the equivalent office having jurisdiction over the foreign bidder's affairs in the Philippines. For Contracting Parties to the Apostille Convention, only the translated documents shall be authenticated through an apostille pursuant to GPPB Resolution No. 13-2019 dated 23 May 2019. The English translation shall govern, for purposes of interpretation of the bid.
- 10.3. A valid Electrical PCAB License or Offshore Engineering or special PCAB License in case of Joint Ventures, and registration for the type and cost of the contract for this Project.
- 10.4. A List of Contractor's key personnel (e.g., Project Manager, Project Engineers, Materials Engineers, and Foremen) assigned to the contract to be bid, with their complete qualification and experience data shall be provided. These key personnel must meet the required minimum years of experience set in the **BDS.**

- 10.5. A List of Contractor's major equipment units, which are owned, leased, and/or under purchase agreements, supported by proof of ownership, certification of availability of equipment from the equipment lessor/vendor for the duration of the project, as the case may be, must meet the minimum requirements for the contract set in the **BDS**.

11. Documents Comprising the Bid: Financial Component

- 11.1. The second bid envelope shall contain the financial documents for the Bid as specified in **Section IX. Checklist of Technical and Financial Documents**.
- 11.2. Any bid exceeding the ABC indicated in paragraph 1 of the **IB** shall not be accepted.
- 11.3. For Foreign-funded procurement, a ceiling may be applied to bid prices provided the conditions are met under Section 31.2 of the 2016 revised IRR of RA No. 9184.

12. Alternative Bids

Bidders shall submit offers that comply with the requirements of the Bidding Documents, including the basic technical design as indicated in the drawings and specifications. Unless there is a value engineering clause in the **BDS**, alternative Bids shall not be accepted.

13. Bid Prices

All bid prices for the given scope of work in the Project as awarded shall be considered as fixed prices, and therefore not subject to price escalation during contract implementation, except under extraordinary circumstances as determined by the Coop and approved by NEA pursuant to the revised Guidelines for Contract Price Escalation guidelines.

14. Bid and Payment Currencies

- 14.1. Bid prices may be quoted in the local currency or tradeable currency accepted by the BSP at the discretion of the Bidder. However, for purposes of bid evaluation, Bids denominated in foreign currencies shall be converted to Philippine currency based on the exchange rate as published in the BSP reference rate bulletin on the day of the bid opening.
- 14.2. Payment of the contract price shall be made in Philippine Pesos.

15. Bid Security

- 15.1. The Bidder shall submit Bid Security in the amount indicated in the **BDS**, which shall be not less than the percentage of the ABC in accordance with the schedule in the **BDS**.

- 15.2. The Bid and bid security shall be valid until for a period of one hundred twenty (120) calendar days from the date of the opening of bids.
- 15.3. Any bid not accompanied by an acceptable bid security shall be rejected by the Procuring Entity as non-responsive.

16. Sealing and Marking of Bids

Each Bidder shall submit three (3) copies of the first and second components of its Bid.

The Procuring Entity may request additional hard copies and/or electronic copies of the Bid. However, failure of the Bidders to comply with the said request shall not be a ground for disqualification.

17. Deadline for Submission of Bids

- 17.1. The bidders shall submit their bids on the specified date, time, and address as indicated in the ITB.
- 17.2. Unsealed or unmarked bid envelopes shall be rejected.
- 17.3. Bids, including the eligibility requirements, submitted after the deadline shall not be accepted by the BANELCO BAC.

18. Opening and Preliminary Examination of Bids

- 18.1. The BAC shall open the Bids in public at the time, on the date, and at the place specified in the **ITB**. The Bidders' representatives who are present shall sign a register evidencing their attendance.

In case the Bids cannot be opened as scheduled due to justifiable reasons, the rescheduling requirements under Section 29 of the 2016 revised IRR of RA No. 9184 shall prevail.

- 18.2. The preliminary examination of bids shall be governed by Section 30 of the 2016 revised IRR of RA No. 9184.
- 18.3. The eligibility requirements and bid proposals shall be evaluated using a non-discretionary "pass/fail" criterion.
- 18.4. In the opening of bids, the Two Envelope System shall be adopted.
- 18.5. Envelope 1, containing the Eligibility Requirements (Class A and B documents) and the Bid Security, shall be opened in the following order:

Folder 1	Legal Documents
Folder 2	Technical Documents
Folder 3	Financial Documents
Folder 4	Class "B" Documents

Folder 5 Bid Securities in the prescribed form, amount and validity period

- 18.6. The second envelope (Envelope 2) containing the Bid Proposal of bidders that were rated failed or ineligible shall no longer be opened and should be returned to the bidder.
- 18.7. After determining compliance with the requirements in the first envelope, the second envelope (Envelope 2) of each remaining eligible bidder whose first envelope was rated “passed” shall be opened in the following order:
Folder 1 Technical Proposal
Folder 2 Financial Proposal
- 18.8. The bidder whose Technical Proposal passed the technical requirements and specifications shall be rated as “passed”, after which Folder 2 of the second envelope containing the financial proposal shall be opened.
- 18.9. Financial Proposals (Folder 2) higher than the ABC shall be outrightly disqualified.
- 18.10. In case any of the requirements in the second envelope is missing, incomplete or patently insufficient, and/or if the submitted total bid price exceeds the ABC, the BANELCO BAC shall rate the bid concerned as “failed.”

19. Detailed Evaluation and Comparison of Bids

- 19.1. The Procuring Entity’s BAC shall immediately conduct a detailed evaluation of all Bids rated “*passed*,” using non-discretionary pass/fail criteria. The BAC shall consider the conditions in the evaluation of Bids under Section 32.2 of the 2016 revised IRR of RA No. 9184.
- 19.2. The BANELCO BAC shall conduct a detailed evaluation of all bids using a non-discretionary criteria considering the following:
 - a. Completeness of the Bid – Partial bids shall not be allowed. Bids not addressing or providing all of the required items in the Bidding Documents including, where applicable, bill of quantities, shall be considered non-responsive and, thus, automatically disqualified. In this regard, where a required item is provided, but no price is indicated, the same shall be considered as non-responsive, but specifying a zero (0) or a dash (-) for the said item would mean that it is being offered for free.
 - b. Arithmetical Corrections - Consider computational errors and omissions to enable proper comparison of all eligible bids. It may also consider bid modifications if expressly allowed in the Bidding Documents. Any adjustment shall be calculated in monetary terms to determine the calculated prices.
- 19.3. The BANELCO BAC shall evaluate all bids on an equal footing to ensure fair and competitive bid comparison. For this purpose, all bidders shall be required

to include the cost of all taxes such as but not limited to Value Added Tax (VAT), income tax, local taxes, and other fiscal levies and duties, which shall be itemized in the bid form and reflected in the detailed estimates. Such bids, including taxes, shall be the bases for bid evaluation, comparison, and for determining the Lowest Calculated Bid (LCB).

19.4. In case of discrepancies between:

Figures against words	- Words shall prevail
Total price per item against unit price for the item multiplied by the quantity of that item	- Price per item multiplied by the quantity shall prevail
Stated total price against the actual sum of prices of component items	- Actual sum of prices of component items shall prevail
Unit cost in the detailed estimate against unit cost in the bill of quantities	- Unit cost in its bill of quantities shall prevail

19.5. Bids shall then be ranked in the ascending order of their total calculated bid prices, as evaluated and corrected for computational errors, and other bid modifications to identify the LCB. Total calculated bid prices, as evaluated and corrected for computational errors, and other bid modifications, which exceed the ABC shall be disqualified.

19.6. The Contract(s) shall be awarded on a per item basis.

19.7. The bid which is determined to be the LCB for a particular item shall be subjected to post-qualification.

19.8. The descriptions of the lots or items shall be indicated in **Section VI (Technical Specifications)**, although the ABCs of these lots or items are indicated in the **BDS** for purposes of the NFCC computation pursuant to Section 23.4.2.6 of the 2016 revised IRR of RA No. 9184. The NFCC must be sufficient for the total of the ABCs for all the lots or items participated in by the prospective Bidder.

20. Post Qualification

20.1. The BANELCO BAC shall notify the Bidder which has the LCB that it shall undergo post-qualification. Whenever required and within the period stated in the notice, the bidder shall submit to the BANELCO BAC its latest income and business tax returns, and other appropriate licenses and permits required by law and as stated in the Checklist of Eligibility Requirements.

20.2. The objectives of the post-qualification include but shall not be limited to:

- 20.2.1 To verify, validate, and ascertain all statements made and documents submitted by the bidder with the LCB, as stated in the bidding documents;
 - 20.2.2 To determine whether the Bidder with the LCB complies with and is responsive to all the requirements and conditions as specified in the Bidding Documents; and
 - 20.2.3 To declare the Lowest Calculated Responsive Bid (LCRB) and recommend to the HOPE the award of contract for the said bidder at its calculated bid price.
- 20.3. If the bidder with the LCB fails the criteria for post-qualification, the BANELCO BAC shall notify the said bidder in writing of its post-disqualification and the grounds for it.
- 20.4. Immediately after the BANELCO BAC has notified the first bidder of its post disqualification, and notwithstanding any pending request for reconsideration thereof, the BANELCO BAC shall initiate and complete the same post-qualification process on the bidder with the second LCB. If the second bidder passes the post-qualification, and provided that the request for reconsideration of the first bidder has been denied, the second bidder shall be post-qualified as the bidder with the LCRB.
- 20.5. If the second bidder, however, fails the post-qualification, the procedure for post-qualification shall be repeated for the bidder with the next LCB and so on until the LCRB is determined for award.
- 20.6 Within three (3) calendar days from receipt by the bidder of the notice from the BAC that the bidder has the Lowest Calculated Bid, the bidder shall submit the following documentary requirements to the BAC;
- a) Latest income and business tax returns;
 - b) Certificate of PhilGEPS Registration; and
 - c) Other appropriate licenses and permits required by law and stated in the Bidding Documents.

Failure to submit the above requirements on time or a finding against the veracity of such shall be ground for the forfeiture of the bid security and disqualify the bidder for award.

21. Notice of Award

- 21.1. Within three (3) calendar days from the issuance of the BANELCO BAC resolution recommending award of the contract for a particular item or item(s), the BANELCO BAC shall notify all other Bidders in writing, whether through physical or electronic means, of its recommendation.
- 21.2. Within a period not exceeding fifteen (15) calendar days from the determination by the BANELCO BAC of the bidder with LCRB or Single Calculated Responsive Bid (SCRB) and the recommendation to award the contract for a

particular item or item(s), the HOPE or its duly authorized representative shall approve or disapprove such recommendation.

- 21.3. In case of approval, the HOPE or its duly authorized representative, shall immediately issue the Notice of Award to the bidder with the LCRB and SCRB and require the posting of Performance Securities.
- 21.4. In the event of disapproval, which shall be based on valid, reasonable, and justifiable grounds as provided for under Section 41 of the IRR of RA 9184, the HoPE shall notify the BAC and the Bidder in writing of such decision and the grounds for it. When applicable, the BAC shall conduct a post-qualification of the Bidder with the next Lowest Calculated Bid. A request for reconsideration may be filed by the bidder with the HoPE in accordance with Section 37.1.3 of the IRR of RA 9184.
- 21.5. A request for reconsideration may be filed by the bidder with the HOPE within three (3) calendar days from receipt of the Notice of Disapproval. The HOPE shall resolve with finality the request for reconsideration within seven (7) calendar days from the filing thereof and furnish the bidder a copy of the resolution immediately from its promulgation.
- 21.6. In no case shall a request for reconsideration stay or delay the bidding process. However, the request for reconsideration must first be resolved before any award is made.
- 21.7. Within fifteen (15) calendar days from receipt of by the winning bidder of the Notice of Award, the following conditions should be complied with:
 - 21.7.1 Submission of the valid Joint Venture Agreement (JVA), if applicable;
 - 21.7.2 Posting of performance securities in accordance with Section 7.1 of the GCC.

22. Signing of the Contract

- 22.1. The documents required in Section 37.2 of the 2016 revised IRR of RA No. 9184 shall form part of the Contract. Additional Contract documents are indicated in the **BDS**.
- 22.2. The Procuring Entity shall enter into a Framework Agreement with the successful Bidder within the same ten (10) calendar day period provided that all the documentary requirements are complied with.

Section III. Bid Data Sheet

Bid Data Sheet

ITB Clause							
5.5	For the purpose of this bidding a similar contract or project shall mean contracts for the Supply, Delivery and Installation of On-shore Cable Protection, Primary Metering, Line Conversion and Extension.						
7.1	The Procuring Entity has prescribed that Subcontracting is not allowed.						
10.3	A valid PCAB License in Electrical or Offshore Engineering or Special PCAB in case of joint ventures, and registration for the type and cost of the contract for this Project						
10.4	<p>The key personnel must meet the required minimum years of experience set below:</p> <p>Project Manager, Project Engineers, Materials Engineers, and Foremen) assigned to the contract to be bid, with their complete qualification and experience data shall be provided. These key personnel must meet the required minimum years of experience set.</p> <p>The minimum work experience requirements for key personnel are the following:</p> <table style="width: 100%; border-collapse: collapse;"> <thead> <tr> <th style="text-align: left; border-bottom: 1px solid black;"><u>Key Personnel</u></th> <th style="text-align: left; border-bottom: 1px solid black;"><u>General Experience</u></th> <th style="text-align: left; border-bottom: 1px solid black;"><u>Relevant Experience</u></th> </tr> </thead> <tbody> <tr> <td style="height: 40px;"></td> <td></td> <td></td> </tr> </tbody> </table>	<u>Key Personnel</u>	<u>General Experience</u>	<u>Relevant Experience</u>			
<u>Key Personnel</u>	<u>General Experience</u>	<u>Relevant Experience</u>					
10.5	List of Contractor's major equipment units, which are owned, leased, and/or under purchase agreements, supported by proof of ownership, certification of availability of equipment from the equipment lessor/vendor for the duration of the project, as the case may be, must meet the minimum requirements for the contract.						
12	Bidders shall submit offers that comply with the requirements of the Bidding Documents, including the basic technical design as indicated in the drawings and specifications. Unless there is a value engineering clause in the BDS , alternative Bids shall not be accepted.						
15.1	<p>The bid security shall be in the following amount:</p> <p>a. The amount of <u>PhP 118,501.50</u> [2% of ABC], if bid security is in cash, cashier's/manager's check, bank draft/guarantee or irrevocable letter of credit;</p> <p>b. The amount of <u>PhP 296,253.75</u> [5% of ABC] if bid security is in Surety Bond; or</p> <p>Any combination of the foregoing proportionates to the share of form with respect to total amount of security.</p>						

15.2	Bids and bid securities shall be valid for a reasonable period as determined by the HoPE concerned, which shall be indicated in the Bidding Documents, but in no case shall the period exceed one hundred twenty (120) calendar days from the date of the opening of bids.
18.5	<p>The following income and business tax returns shall be required:</p> <ol style="list-style-type: none"> 1. 2023 Income Tax Return and proof of payment; 2. Value Added Tax Returns (Forms 2550M and 2550Q) or Percentage Tax Returns (Form 2551M) and proof of payments thereof covering the months (May 2024- October 2024). <p>The income tax and business tax returns stated above should have been filed through the Electronic Filing and Payments System (EFPS).</p> <p>Proofs of payment are as follows:</p> <p>EFPS Confirmation receipt; or</p> <p>Bank issued payment confirmation receipt; or</p> <p>BIR payment status BIR payment status</p>
21	Additional contract documents relevant to the Project that may be required by existing laws and/or the Procuring Entity, such as construction schedule and S-curve, manpower schedule, construction methods, equipment utilization schedule, construction safety and health program approved by the DOLE, and other acceptable tools of project scheduling.

Section IV. General Conditions of Contract

1 Definitions

For purposes of this Clause, boldface type is used to identify defined terms.

- 1.1 The **Arbiter** is the person appointed jointly by the Procuring Entity and the Contractor to resolve disputes in the first instance, as provided for in **GCC** Clause 21.
- 1.2 **Bill of Quantities** refers to a list of the specific items of the Work and their corresponding unit prices, lump sums, and/or provisional sums.
- 1.3 The **Completion Date** is the date of completion of the Works as certified by the Procuring Entity's Representative, in accordance with **GCC** Clause 49.
- 1.4 The **Contract** is the contract between the Procuring Entity and the Contractor to execute, complete, and maintain the Works.
- 1.5 The **Contract Effectivity Date** is the date of signing of the Contract. However, the contractor shall commence execution of the Works on the Start Date as defined in **GCC** Clause 1.28.
- 1.6 The **Contract Price** is the price stated in the Notice of Award and thereafter to be paid by the Procuring Entity to the Contractor for the execution of the Works in accordance with this Contract
- 1.7 **Contract Time Extension** is the allowable period for the Contractor to complete the Works in addition to the original Completion Date stated in this Contract.
- 1.8 The **Contractor** is the juridical entity whose proposal has been accepted by the Procuring Entity and to whom the Contract to execute the Work was awarded.
- 1.9 The **Contractor's Bid** is the signed offer or proposal submitted by the Contractor to the Procuring Entity in response to the Bidding Documents.
- 1.10 **Days** are calendar days; months are calendar months.
- 1.11 Dayworks are varied work inputs subject to payment on a time basis for the Contractor's employees and Equipment, in addition to payments for associated Materials and Plant.
- 1.12 A **Defect** is any part of the Works not completed in accordance with the Contract.
- 1.13 The **Defects Liability Certificate** is the certificate issued by Procuring Entity's Representative upon correction of defects by the Contractor.
- 1.14 The **Defects Liability Period** is one (1) year period between contract completion and final acceptance within which the Contractor assumes the responsibility to undertake the repair of any damage to the Works at his own expense.

- 1.15 **Drawings** are graphical presentations of the Works. They include all supplementary details, shop drawings, calculations, and other information provided or approved for the execution of this Contract.
- 1.16 **Equipment** refers to all facilities, supplies, appliances, materials or things required for the execution and completion of the Work provided by the Contractor and which shall not form or are not intended to form part of the Permanent Works.
- 1.17 The **Intended Completion Date** refers to the date specified in the SCC when the Contractor is expected to have completed the Works. The Intended Completion Date may be revised only by the Procuring Entity's Representative by issuing an extension of time or an acceleration order.
- 1.18 **Materials** are all supplies, including consumables, used by the Contractor for incorporation in the Works.
- 1.19 The **Notice to Proceed** is a written notice issued by the Procuring Entity or the Procuring Entity's Representative to the Contractor requiring the latter to begin the commencement of the work not later than a specified or determinable date.
- 1.20 **Permanent Works** are all permanent structures and all other project features and facilities required to be constructed and completed in accordance with this Contract which shall be delivered to the Procuring Entity and which shall remain at the Site after the removal of all Temporary Works.
- 1.21 **Plant** refers to the machinery, apparatus, and the like intended to form an integral part of the Permanent Works.
- 1.22 The **Procuring Entity** is the party who employs the Contractor to carry out the Works stated in the SCC.
- 1.23 The **Procuring Entity's Representative** refers to the Head of the Procuring Entity or his duly authorized representative, identified in the SCC, who shall be responsible for supervising the execution of the Works and administering this Contract.
- 1.24 The **Site** is the place provided by the Procuring Entity where the Works shall be executed and any other place or places which may be designated in the SCC, or notified to the Contractor by the Procuring Entity's Representative as forming part of the Site.
- 1.25 **Site Investigation Reports** are those that were included in the Bidding Documents and are factual and interpretative reports about the surface and subsurface conditions at the Site.
- 1.26 **Slippage** is a delay in work execution occurring when actual accomplishment falls below the target as measured by the difference between the scheduled and actual accomplishment of the Work by the Contractor as established from the work schedule. This is actually described as a percentage of the whole Works.

- 1.27 **Specifications** means the description of Works to be done and the qualities of materials to be used, the equipment to be installed and the mode of construction.
- 1.28 The **Start Date**, as specified in the **SCC**, is the date when the Contractor is obliged to commence execution of the Works. It does not necessarily coincide with any of the Site Possession Dates.
- 1.29 A **Subcontractor** is any person or organization to whom a part of the Works has been subcontracted by the Contractor, as allowed by the Procuring Entity, but not any assignee of such person.
- 1.30 **Temporary Works** are works designed, constructed, installed, and removed by the Contractor that are needed for construction or installation of the Permanent Works.
- 1.31 **Work(s)** refer to the Permanent Works and Temporary Works to be executed by the Contractor in accordance with this Contract, including (i) the furnishing of all labor, materials, equipment and others incidental, necessary or convenient to the complete execution of the Works; (ii) the passing of any tests before acceptance by the Procuring Entity's Representative; (iii) and the carrying out of all duties and obligations of the Contractor imposed by this Contract as described in the **SCC**.

2 Interpretation

- 2.1 In interpreting the Conditions of Contract, singular also means plural, male also means female or neuter, and the other way around. Headings have no significance. Words have their normal meaning under the language of this Contract unless specifically defined. The Procuring Entity's Representative will provide instructions clarifying queries about the Conditions of Contract.
- 2.2 If sectional completion is specified in the **SCC**, references in the Conditions of Contract to the Works, the Completion Date, and the Intended Completion Date apply to any Section of the Works (other than references to the Completion Date and Intended Completion Date for the whole of the Works).
- 2.3 The documents forming this Contract shall be interpreted in the following order of priority:
- a) Contract Agreement;
 - b) Bid Data Sheet;
 - c) Instructions to Bidders;
 - d) Addenda to the Bidding Documents;
 - e) Special Conditions of Contract;
 - f) General Conditions of Contract;
 - g) Specifications;

- h) Bill of Quantities; and
- i) Drawings.

3 Governing Language and Law

3.1 This Contract has been executed in the English language, which shall be the binding and controlling language for all matters relating to the meaning or interpretation of this Contract. All correspondence and other documents pertaining to this Contract which are exchanged by the parties shall be written in English.

3.2 This Contract shall be interpreted in accordance with the laws of the Republic of the Philippines.

4 Communications

Communications between parties that are referred to in the Conditions shall be effective only when in writing. A notice shall be effective only when it is received by the concerned party.

5 Possession of Site

5.1 On the date specified in the **SCC**, the Procuring Entity shall grant the Contractor possession of so much of the Site as may be required to enable it to proceed with the execution of the Works. If the Contractor suffers delay or incurs cost from failure on the part of the Procuring Entity to give possession in accordance with the terms of this clause, the Procuring Entity's Representative shall give the Contractor a Contract Time Extension and certify such sum as fair to cover the cost incurred, which sum shall be paid by Procuring Entity.

5.2 If possession of a portion is not given by the date stated in the SCC Clause 5.1, the Procuring Entity will be deemed to have delayed the start of the relevant activities. The resulting adjustments in contract time to address such delay shall be in accordance with **GCC** Clause 47.

5.3 The Contractor shall bear all costs and charges for special or temporary right-of-way required by it in connection with access to the Site. The Contractor shall also provide at his own cost any additional facilities outside the Site required by it for purposes of the Works.

5.4 The Contractor shall allow the Procuring Entity's Representative and any person authorized by the Procuring Entity's Representative access to the Site and to any place where work in connection with this Contract is being carried out or is intended to be carried out.

6 The Contractor's Obligations

6.1 The Contractor shall carry out the Works properly and in accordance with this Contract. The Contractor shall provide all supervision, labor, Materials, Plant and Contractor's Equipment, which may be required. All Materials and Plant on Site shall be deemed to be the property of the Procuring Entity.

- 6.2 The Contractor shall commence execution of the Works on the Start Date and shall carry out the Works in accordance with the Program of Work submitted by the Contractor, as updated with the approval of the Procuring Entity's Representative, and complete them by the Intended Completion Date.
- 6.3 The Contractor shall be responsible for the safety of all activities on the Site.
- 6.4 The Contractor shall carry out all instructions of the Procuring Entity's Representative that comply with the applicable laws where the Site is located.
- 6.5 The Contractor shall employ the key personnel named in the Schedule of Key Personnel, as referred to in the **SCC**, to carry out the supervision of the Works. The Procuring Entity will approve any proposed replacement of key personnel only if their relevant qualifications and abilities are equal to or better than those of the personnel listed in the Schedule.
- 6.6 If the Procuring Entity's Representative asks the Contractor to remove a member of the Contractor's staff or work force, for justifiable cause, the Contractor shall ensure that the person leaves the Site within seven (7) days and has no further connection with the Work in this Contract.
- 6.7 During Contract implementation, the Contractor and his subcontractors shall abide at all times by all labor laws, including child labor related enactments, and other relevant rules.
- 6.8 The Contractor shall submit to the Procuring Entity for consent the name and particulars of the person authorized to receive instructions on behalf of the Contractor.
- 6.9 The Contractor shall cooperate and share the Site with other contractors, public authorities, utilities, and the Procuring Entity between the dates given in the schedule of other contractors particularly when they shall require access to the Site. The Contractor shall also provide facilities and services for them during this period. The Procuring Entity may modify the schedule of other contractors, and shall notify the Contractor of any such modification thereto.
- 6.10 Should anything of historical or other interest or of significant value be unexpectedly discovered on the Site, it shall be the property of the Procuring Entity. The Contractor shall notify the Procuring Entity's Representative of such discoveries and carry out the Procuring Entity's Representative's instructions in dealing with them.

7 Performance Security

- 7.1 Within ten (10) calendar days from receipt of the Notice of Award from the Procuring Entity but in no case later than the signing of the contract by both parties, the Contractor shall furnish the performance security in any of the forms prescribed;

Form of Performance Security	Amount of Performance Security (Not less than the Percentage of the Total Contract Price)
(a) Cash or cashier's/manager's check issued by a Universal or Commercial Bank.	Ten percent (10%)
(b) Bank draft/guarantee or irrevocable letter of credit issued by a Universal or Commercial Bank: Provided, however, that it shall be confirmed or authenticated by a Universal or Commercial Bank, if issued by a foreign bank.	Ten percent (10%)
(c) Surety bond callable upon demand issued by a surety or insurance company duly certified by the Insurance Commission as authorized to issue such security.	Thirty percent (30%)

7.2 The performance security posted in favor of the Procuring Entity shall be forfeited in the event it is established that the Contractor is in default in any of its obligations under the Contract.

7.3 The performance security shall remain valid until issuance by the Procuring Entity of the Certificate of Final Acceptance.

7.4 The performance security may be released by the Procuring Entity and returned to the Contractor after the issuance of the Certificate of Final Acceptance subject to the following conditions:

7.4.1 There are no pending claims against the Contractor or the surety company filed by the Procuring Entity;

7.4.2 The Contractor has no pending claims for labor and materials filed against it; and

7.4.3 Other terms specified in the SCC.

7.5 The Contractor shall post an additional performance security following the amount and form specified in **GCC** Clause 7.1 to cover any cumulative increase of more than ten percent (10%) over the original value of the contract as a result of amendments to order or change orders, extra work orders and supplemental agreements, as the case may be. The Contractor shall cause the extension of the validity of the performance security to cover approved contract time extensions.

7.6 In case of a reduction in the contract value or for partially completed Works under the contract which are usable and accepted by the Procuring Entity the use

of which, in the judgment of the implementing agency or the Procuring Entity, will not affect the structural integrity of the entire project, the Procuring Entity shall allow a proportional reduction in the original performance security, provided that any such reduction is more than ten percent (10%) and that the aggregate of such reductions is not more than fifty percent (50%) of the original performance security.

7.7 Unless otherwise indicated in the **SCC**, the Contractor, by entering into the Contract with the Procuring Entity, acknowledges the right of the Procuring Entity to institute action pursuant to Act 3688 against any subcontractor be they an individual, firm, partnership, corporation, or association supplying the Contractor with labor, materials and/or equipment for the performance of this Contract.

8 Subcontracting

8.1 Unless otherwise indicated in the **SCC**, the Contractor cannot subcontract Works more than the percentage specified in **BDS**.

8.2 Subcontracting of any portion of the Works does not relieve the Contractor of any liability or obligation under this Contract. The Contractor will be responsible for the acts, defaults, and negligence of any subcontractor, its agents, servants or workmen as fully as if these were the Contractor's own acts, defaults, or negligence, or those of its agents, servants or workmen.

8.3 If subcontracting is allowed. The contractor may identify its subcontractor during contract implementation stage. Subcontractors disclosed and identified during the bidding may be changed during the implementation of this Contract. In either case, subcontractors must submit the documentary requirements and comply with the eligibility criteria specified Section IX of the Bidding Documents. In the event that any subcontractor is found by any Procuring Entity to be eligible, the subcontracting of such portion of the Works shall be disallowed.

9 Liquidated Damages

9.1 The Contractor shall pay liquidated damages to the Procuring Entity for each day that the Completion Date is later than the Intended Completion Date. The applicable liquidated damages is at least one-tenth (1/10) of a percent of the cost of the unperformed portion for every day of delay. The total amount of liquidated damages shall not exceed ten percent (10%) of the amount of the contract. The Procuring Entity may deduct liquidated damages from payments due to the Contractor. Payment of liquidated damages shall not affect the Contractor's liabilities. Once the cumulative amount of liquidated damages reaches ten percent (10%) of the amount of this Contract, the Procuring Entity may rescind or terminate this Contract, without prejudice to other courses of action and remedies available under the circumstances.

9.2 If the Intended Completion Date is extended after liquidated damages have been paid, the Engineer of the Procuring Entity shall correct any overpayment of liquidated damages by the Contractor by adjusting the next payment certificate.

10 Site Investigation Reports

The Contractor, in preparing the Bid, shall rely on any Site Investigation Reports referred to in the SCC supplemented by any information obtained by the Contractor.

11 The Procuring Entity, Licenses and Permits

The Procuring Entity shall, if requested by the Contractor, assist him in applying for permits, licenses or approvals, which are required for the Works.

12 Contractor's Risk and Warranty Security

12.1 The Contractor shall assume full responsibility for the Works from the time project construction commenced up to final acceptance by the Procuring Entity and shall be held responsible for any damage or destruction of the Works except those occasioned by *force majeure*. The Contractor shall be fully responsible for the safety, protection, security, and convenience of his personnel, third parties, and the public at large, as well as the Works, Equipment, installation, and the like to be affected by his construction work.

12.2 The defects liability period for infrastructure projects shall be one year from contract completion up to final acceptance by the Procuring Entity. During this period, the Contractor shall undertake the repair works, at his own expense, of any damage to the Works on account of the use of materials of inferior quality within ninety (90) days from the time the HoPE has issued an order to undertake repair. In case of failure or refusal to comply with this mandate, the Procuring Entity shall undertake such repair works and shall be entitled to full reimbursement of expenses incurred therein upon demand.

12.3 Unless otherwise indicated in the SCC, in case the Contractor fails to comply with the preceding paragraph, the Procuring Entity shall forfeit its performance security, subject its property(ies) to attachment or garnishment proceedings, and perpetually disqualify it from participating in any public bidding. All payables of the GoP in his favor shall be offset to recover the costs.

12.4 After final acceptance of the Works by the Procuring Entity, the Contractor shall be held responsible for "Structural Defects," *i.e.*, major faults/flaws/deficiencies in one or more key structural elements of the project which may lead to structural failure of the completed elements or structure, or "Structural Failures," *i.e.*, where one or more key structural elements in an infrastructure facility fails or collapses, thereby rendering the facility or part thereof incapable of withstanding the design loads, and/or endangering the safety of the users or the general public:

12.4.1 Contractor – Where Structural Defects/Failures arise due to faults attributable to improper construction, use of inferior quality/substandard materials, and any violation of the contract plans and specifications, the contractor shall be held liable;

12.4.2 Consultants – Where Structural Defects/Failures arise due to faulty and/or inadequate design and specifications as well as construction

supervision, then the consultant who prepared the design or undertook construction supervision for the project shall be held liable;

12.4.3 Procuring Entity’s Representatives/Project Manager/Construction Managers and Supervisors – The project owner’s representative(s), project manager, construction manager, and supervisor(s) shall be held liable in cases where the Structural Defects/Failures are due to his/their willful intervention in altering the designs and other specifications; negligence or omission in not approving or acting on proposed changes to noted defects or deficiencies in the design and/or specifications; and the use of substandard construction materials in the project;

12.4.4 Third Parties - Third Parties shall be held liable in cases where Structural Defects/Failures are caused by work undertaken by them such as leaking pipes, diggings or excavations, underground cables and electrical wires, underground tunnel, mining shaft and the like, in which case the applicable warranty to such structure should be levied to third parties for their construction or restoration works.

12.4.5 Users - In cases where Structural Defects/Failures are due to abuse/misuse by the end user of the constructed facility and/or non-compliance by a user with the technical design limits and/or intended purpose of the same, then the user concerned shall be held liable.

12.5 The warranty against Structural Defects/Failures, except those occasioned-on force majeure, shall cover the period specified in the **SCC** reckoned from the date of issuance of the Certificate of Final Acceptance by the Procuring Entity.

12.6 The Contractor shall be required to put up a warranty security in the form of cash, bank guarantee, letter of credit, GSIS or surety bond callable on demand, in accordance with the following schedule:

Form of Warranty	Amount of Warranty Security Not less than the Percentage (%) of Total Contract Price
<p>a. Cash or letter of credit issued by Universal or Commercial bank: provided, however, that the letter of credit shall be confirmed or authenticated by a Universal or Commercial bank, if issued by a foreign bank</p>	<p>Five Percent (5%)</p>
<p>b. Bank guarantee confirmed by Universal or Commercial bank: provided, however, that the letter of credit shall be confirmed or authenticated by a Universal or Commercial bank, if issued by a foreign bank</p>	<p>Ten Percent (10%)</p>

c. Surety bond callable upon demand issued by GSIS or any surety or insurance company duly certified by the Insurance Commission	Thirty Percent (30%)
--	----------------------

12.7 The warranty security shall be stated in Philippine Pesos and shall remain effective for one year from the date of issuance of the Certificate of Final Acceptance by the Procuring Entity, and returned only after the lapse of said one year period.

12.8 In case of structural defects/failure occurring during the applicable warranty period provided in **GCC** Clause 12.5, the Procuring Entity shall undertake the necessary restoration or reconstruction works and shall be entitled to full reimbursement by the parties found to be liable for expenses incurred therein upon demand, without prejudice to the filing of appropriate administrative, civil, and/or criminal charges against the responsible persons as well as the forfeiture of the warranty security posted in favor of the Procuring Entity.

13 Liability of the Contractor

Subject to additional provisions, if any, set forth in the **SCC**, the Contractor's liability under this Contract shall be as provided by the laws of the Republic of the Philippines.

14 Procuring Entity's Risk

14.1 From the Start Date until the Certificate of Final Acceptance has been issued, the following are risks of the Procuring Entity:

14.1.1 The risk of personal injury, death, or loss of or damage to property (excluding the Works, Plant, Materials, and Equipment), which are due to:

- a. any type of use or occupation of the Site authorized by the Procuring Entity after the official acceptance of the works; or
- b. negligence, breach of statutory duty, or interference with any legal right by the Procuring Entity or by any person employed by or contracted to him except the Contractor.

14.1.2 The risk of damage to the Works, Plant, Materials, and Equipment to the extent that it is due to a fault of the Procuring Entity or in the Procuring Entity's design, or due to war or radioactive contamination directly affecting the country where the Works are to be executed.

15 Insurance

15.1 The Contractor shall, under his name and at his own expense, obtain and maintain, for the duration of this Contract, the following insurance coverage:

- a. Contractor's All Risk Insurance;

- b. Transportation to the project Site of Equipment, Machinery, and Supplies owned by the Contractor;
- c. Personal injury or death of Contractor's employees; and
- d. Comprehensive insurance for third party liability to Contractor's direct or indirect act or omission causing damage to third persons.

15.2 The Contractor shall provide evidence to the Procuring Entity's Representative that the insurances required under this Contract have been effected and shall, within a reasonable time, provide copies of the insurance policies to the Procuring Entity's Representative. Such evidence and such policies shall be provided to the Procuring Entity's through the Procuring Entity's Representative.

15.3 The Contractor shall notify the insurers of changes in the nature, extent, or program for the execution of the Works and ensure the adequacy of the insurances at all times in accordance with the terms of this Contract and shall produce to the Procuring Entity's Representative the insurance policies in force including the receipts for payment of the current premiums.

The above insurance policies shall be obtained from any reputable insurance company approved by the Procuring Entity's Representative.

15.4 If the Contractor fails to obtain and keep in force the insurances referred to herein or any other insurance which he may be required to obtain under the terms of this Contract, the Procuring Entity may obtain and keep in force any such insurances and pay such premiums as may be necessary for the purpose. From time to time, the Procuring Entity may deduct the amount it shall pay for said premiums including twenty five percent (25%) therein from any monies due, or which may become due, to the Contractor, without prejudice to the Procuring Entity exercising its right to impose other sanctions against the Contractor pursuant to the provisions of this Contract.

15.5 In the event the Contractor fails to observe the above safeguards, the Procuring Entity may, at the Contractor's expense, take whatever measure is deemed necessary for its protection and that of the Contractor's personnel and third parties, and/or order the interruption of dangerous Works. In addition, the Procuring Entity may refuse to make the payments under GCC Clause 40 until the Contractor complies with this Clause.

15.6 The Contractor shall immediately replace the insurance policy obtained as required in this Contract, without need of the Procuring Entity's demand, with a new policy issued by a new insurance company acceptable to the Procuring Entity for any of the following grounds:

- a. The issuer of the insurance policy to be replaced has:
 - i. become bankrupt;
 - ii. been placed under receivership or under a management committee;

- iii. been sued for suspension of payment; or
- iv. been suspended by the Insurance Commission and its license to engage in business or its authority to issue insurance policies cancelled; or
- v. Where reasonable grounds exist that the insurer may not be able, fully and promptly, to fulfill its obligation under the insurance policy.

16 Termination for Default of Contractor

16.1 The Procuring Entity shall terminate this Contract for default when any of the following conditions attend its implementation:

16.1.1 Due to the Contractor's fault and while the project is on-going, it has incurred negative slippage of fifteen percent (15%) or more in accordance with Presidential Decree 1870, regardless of whether or not previous warnings and notices have been issued for the Contractor to improve his performance;

16.1.2 Due to its own fault and after this Contract time has expired, the Contractor incurs delay in the completion of the Work after this Contract has expired; or

16.1.3 The Contractor:

- a. abandons the contract Works, refuses or fails to comply with a valid instruction of the Procuring Entity or fails to proceed expeditiously and without delay despite a written notice by the Procuring Entity;
- b. does not actually have on the project Site the minimum essential equipment listed on the bid necessary to prosecute the Works in accordance with the approved Program of Work and equipment deployment schedule as required for the project;
- c. does not execute the Works in accordance with this Contract or persistently or flagrantly neglects to carry out its obligations under this Contract;
- d. neglects or refuses to remove materials or to perform a new Work that has been rejected as defective or unsuitable; or
- e. sub-lets any part of this Contract without approval by the Procuring Entity.

16.2 All materials on the Site, Plant, Works, including Equipment purchased and funded under the Contract shall be deemed to be the property of the Procuring Entity if this Contract is rescinded because of the Contractor's default.

17 Termination for Default of Procuring Entity

The Contractor may terminate this Contract with the Procuring Entity if the works are completely stopped for a continuous period of at least sixty (60) calendar days through no fault of its own, due to any of the following reasons:

- a. Failure of the Procuring Entity to deliver, within a reasonable time, supplies, materials, right-of-way, or other items it is obligated to furnish under the terms of this Contract; or
- b. The prosecution of the Work is disrupted by the adverse peace and order situation, as certified by the Armed Forces of the Philippines Provincial Commander and approved by the Secretary of National Defense.

18 Termination for Other Causes

18.1 The Procuring Entity may terminate this Contract, in whole or in part, at any time for its convenience. The HoPE may terminate this Contract for the convenience of the Procuring Entity if he has determined the existence of conditions that make Project Implementation economically, financially or technically impractical and/or unnecessary, such as, but not limited to, fortuitous event(s) or changes in law and National Government policies.

18.2 The Procuring Entity or the Contractor may terminate this Contract if the other party causes a fundamental breach of this Contract.

18.3 Fundamental breaches of Contract shall include, but shall not be limited to, the following:

- a. The Contractor stops work for twenty eight (28) days when no stoppage of work is shown on the current Program of Work and the stoppage has not been authorized by the Procuring Entity's Representative;
- b. The Procuring Entity's Representative instructs the Contractor to delay the progress of the Works, and the instruction is not withdrawn within twenty-eight (28) days;
- c. The Procuring Entity shall terminate this Contract if the Contractor is declared bankrupt or insolvent as determined with finality by a court of competent jurisdiction. In this event, termination will be without compensation to the Contractor, provided that such termination will not prejudice or affect any right of action or remedy which has accrued or will accrue thereafter to the Procuring Entity and/or the Contractor. In the case of the Contractor's insolvency, any Contractor's Equipment which the Procuring Entity instructs in the notice is to be used until the completion of the Works;
- d. A payment certified by the Procuring Entity's Representative is not paid by the Procuring Entity to the Contractor within eighty-four (84) days from the date of the Procuring Entity's Representative's certificate;

- e. The Procuring Entity's Representative Gives Notice that failure to correct a particular Defect is a fundamental breach of Contract and the Contractor fails to correct it within a reasonable period of time determined by the Procuring Entity's Representative;
- f. The Contractor does not maintain a Security, which is required;
- g. The Contractor has delayed the completion of the Works by the number of days for which the maximum amount of liquidated damages can be paid, as defined in the **GCC** Clause 9; and
- h. In case it is determined prima facie by the Procuring Entity that the Contractor has engaged, before or during the implementation of the contract, in unlawful deeds and behaviors relative to contract acquisition and implementation, such as, but not limited to, the following:
 - i. corrupt, fraudulent, collusive, coercive, and obstructive practices as defined in **ITB** Clause 4 unless otherwise specified in the **SCC**;
 - ii. drawing up or using forged documents;
 - iii. using adulterated materials, means or methods, or engaging in production contrary to rules of science or the trade; and
 - iv. any other act analogous to the foregoing.

18.4 The Funding Source or the Procuring Entity, as appropriate, will seek to impose the maximum civil, administrative and/or criminal penalties available under the applicable law on individuals and organizations deemed to be involved with corrupt, fraudulent, or coercive practices.

18.5 When persons from either party to this Contract gives notice of a fundamental breach to the Procuring Entity's Representative in order to terminate the existing contract for a cause other than those listed under **GCC** Clause 18.3, the Procuring Entity's Representative shall decide whether the breach is fundamental or not.

18.6 If this Contract is terminated, the Contractor shall stop work immediately, make the Site safe and secure, and leave the Site as soon as reasonably possible.

19 Procedures for Termination of Contracts

19.1 The following provisions shall govern the procedures for the termination of this Contract:

- a. Upon receipt of a written report of acts or causes which may constitute ground(s) for termination as aforementioned, or upon its own initiative, the Procuring Entity shall, within a period of seven (7) calendar days, verify the existence of such ground(s) and cause the execution of a Verified Report, with all relevant evidence attached;

- b. Upon recommendation by the Procuring Entity, the HoPE shall terminate this Contract only by a written notice to the Contractor conveying the termination of this Contract. The notice shall state:
 - i. that this Contract is being terminated for any of the ground(s) afore-mentioned, and a statement of the acts that constitute the ground(s) constituting the same;
 - ii. the extent of termination, whether in whole or in part;
 - iii. an instruction to the Contractor to show cause as to why this Contract should not be terminated; and
 - iv. special instructions of the Procuring Entity, if any.

The Notice to Terminate shall be accompanied by a copy of the Verified Report;

- c. Within a period of seven (7) calendar days from receipt of the Notice of Termination, the Contractor shall submit to the HoPE a verified position paper stating why the contract should not be terminated. If the Contractor fails to show cause after the lapse of the seven (7) day period, either by inaction or by default, the HoPE shall issue an order terminating the contract;
- d. The Procuring Entity may, at anytime before receipt of the Contractor's verified position paper described in item (c) above withdraw the Notice to Terminate if it is determined that certain items or works subject of the notice had been completed, delivered, or performed before the Contractor's receipt of the notice;
- e. Within a non-extendible period of ten (10) calendar days from receipt of the verified position paper, the HoPE shall decide whether or not to terminate this Contract. It shall serve a written notice to the Contractor of its decision and, unless otherwise provided in the said notice, this Contract is deemed terminated from receipt of the Contractor of the notice of decision. The termination shall only be based on the ground(s) stated in the Notice to Terminate; and
- f. The HoPE may create a Contract Termination Review Committee (CTRC) to assist him in the discharge of this function. All decisions recommended by the CTRC shall be subject to the approval of the HoPE.

19.2 Pursuant to Section 69(f) of RA 9184 and without prejudice to the imposition of additional administrative sanctions as the internal rules of the agency may provide and/or further criminal prosecution as provided by applicable laws, the procuring entity shall impose on contractors after the termination of the contract the penalty of suspension for one (1) year for the first offense, suspension for two (2) years for the second offense from participating in the public bidding

process, for violations committed during the contract implementation stage, which include but not limited to the following:

- a. Failure of the contractor, due solely to his fault or negligence, to mobilize and start work or performance within the specified period in the Notice to Proceed (“NTP”);
- b. Failure by the contractor to fully and faithfully comply with its contractual obligations without valid cause, or failure by the contractor to comply with any written lawful instruction of the procuring entity or its representative(s) pursuant to the implementation of the contract. For the procurement of infrastructure projects or consultancy contracts, lawful instructions include but are not limited *to* the following:
 - i. Employment of competent technical personnel, competent engineers and/or work supervisors;
 - ii. Provision of warning signs and barricades in accordance with approved plans and specifications and contract provisions;
 - iii. Stockpiling in proper places of all materials and removal from the project site of waste and excess materials, including broken pavement and excavated debris in accordance with approved plans and specifications and contract provisions;
 - iv. Deployment of committed equipment, facilities, support staff and manpower; and
 - v. Renewal of the effectivity dates of the performance security after its expiration during the course of contract implementation.
- c. Assignment and subcontracting of the contract or any part thereof or substitution of key personnel named in the proposal without prior written approval by the procuring entity.
- d. Poor performance by the contractor or unsatisfactory quality and/or progress of work arising from his fault or negligence as reflected in the Constructor's Performance Evaluation System (“CPES”) rating sheet. In the absence of the CPES rating sheet, the existing performance monitoring system of the procuring entity shall be applied. Any of the following acts by the Contractor shall be construed as poor performance:
 - i. Negative slippage of 15% and above within the critical path of the project due entirely to the fault or negligence of the contractor; and

- ii. Quality of materials and workmanship not complying with the approved specifications arising from the contractor's fault or negligence.
- e. Willful or deliberate abandonment or non-performance of the project or contract by the contractor resulting to substantial breach thereof without lawful and/or just cause.

In addition to the penalty of suspension, the performance security posted by the contractor shall also be forfeited.

20 Force Majeure, Release from Performance

20.1 For purposes of this Contract the terms “*force majeure*” and “fortuitous event” may be used interchangeably. In this regard, a fortuitous event or *force majeure* shall be interpreted to mean an event which the Contractor could not have foreseen, or which though foreseen, was inevitable. It shall not include ordinary unfavorable weather conditions; and any other cause the effects of which could have been avoided with the exercise of reasonable diligence by the Contractor.

20.2 If this Contract is discontinued by an outbreak of war or by any other event entirely outside the control of either the Procuring Entity or the Contractor, the Procuring Entity’s Representative shall certify that this Contract has been discontinued. The Contractor shall make the Site safe and stop work as quickly as possible after receiving this certificate and shall be paid for all works carried out before receiving it and for any Work carried out afterwards to which a commitment was made.

20.3 If the event continues for a period of eighty-four (84) days, either party may then give notice of termination, which shall take effect twenty-eight (28) days after the giving of the notice.

20.4 After termination, the Contractor shall be entitled to payment of the unpaid balance of the value of the Works executed and of the materials and Plant reasonably delivered to the Site, adjusted by the following:

- a. any sum to which the Contractor is entitled under GCC Clause 28;
- b. the cost of his suspension and demobilization;
- c. any sum to which the Procuring Entity is entitled.

20.5 The net balance due shall be paid or repaid within a reasonable time period from the time of the notice of termination.

21 Resolution of Disputes

21.1 If any dispute or difference of any kind whatsoever shall arise between the parties in connection with the implementation of the contract covered by the Act and this IRR, the parties shall make every effort to resolve amicably such dispute or difference by mutual consultation.

21.2 If the Contractor believes that a decision taken by the Procuring Entity's Representative was either outside the authority given to the Procuring Entity's Representative by this Contract or that the decision was wrongly taken, the decision shall be referred to the Arbiter indicated in the **SCC** within fourteen (14) days of the notification of the Procuring Entity's Representative's decision.

21.3 Any and all disputes arising from the implementation of this Contract covered by the R.A. 9184 and its IRR shall be submitted to arbitration in the Philippines according to the provisions of Republic Act No. 876, otherwise known as the "Arbitration Law" and Republic Act 9285, otherwise known as the "Alternative Dispute Resolution Act of 2004": *Provided, however*, That, disputes that are within the competence of the Construction Industry Arbitration Commission to resolve shall be referred thereto. The process of arbitration shall be incorporated as a provision in this Contract that will be executed pursuant to the provisions of the Act and its IRR: *Provided, further*, That, by mutual agreement, the parties may agree in writing to resort to other alternative modes of dispute resolution.

22 Suspension of Loan, Credit, Grant, or Appropriation

In the event that the Funding Source suspends the Loan, Credit, Grant, or Appropriation to the Procuring Entity, from which part of the payments to the Contractor are being made:

- a. The Procuring Entity is obligated to notify the Contractor of such suspension within seven (7) days of having received the suspension notice.
- b. If the Contractor has not received sums due it for work already done within forty five (45) days from the time the Contractor's claim for payment has been certified by the Procuring Entity's Representative, the Contractor may immediately issue a suspension of work notice in accordance with **GCC** Clause 45.2.

23 Procuring Entity's Representative's Decisions

23.1 Except where otherwise specifically stated, the Procuring Entity's Representative will decide contractual matters between the Procuring Entity and the Contractor in the role representing the Procuring Entity.

23.1 The Procuring Entity's Representative may delegate any of his duties and responsibilities to other people, except to the Arbiter, after notifying the Contractor, and may cancel any delegation after notifying the Contractor.

24 Approval of Drawings and Temporary Works by the Procuring Entity's Representative

24.1 All Drawings prepared by the Contractor for the execution of the Temporary Works, are subject to prior approval by the Procuring Entity's Representative before its use.

24.2 The Contractor shall be responsible for design of Temporary Works.

24.3 The Procuring Entity's Representative's approval shall not alter the Contractor's responsibility for design of the Temporary Works.

24.4 The Contractor shall obtain approval of third parties to the design of the Temporary Works, when required by the Procuring Entity.

25 Acceleration and Delays Ordered by the Procuring Entity's Representative

25.1 When the Procuring Entity wants the Contractor to finish before the Intended Completion Date, the Procuring Entity's Representative will obtain priced proposals for achieving the necessary acceleration from the Contractor. If the Procuring Entity accepts these proposals, the Intended Completion Date will be adjusted accordingly and confirmed by both the Procuring Entity and the Contractor.

25.2 If the Contractor's Financial Proposals for an acceleration are accepted by the Procuring Entity, they are incorporated in the Contract Price and treated as a Variation.

26 Extension of the Intended Completion Date

26.1 The Procuring Entity's Representative shall extend the Intended Completion Date if a Variation is issued which makes it impossible for the Intended Completion Date to be achieved by the Contractor without taking steps to accelerate the remaining work, which would cause the Contractor to incur additional costs. No payment shall be made for any event which may warrant the extension of the Intended Completion Date.

26.2 The Procuring Entity's Representative shall decide whether and by how much to extend the Intended Completion Date within twenty one (21) days of the Contractor asking the Procuring Entity's Representative for a decision thereto after fully submitting all supporting information. If the Contractor has failed to give early warning of a delay or has failed to cooperate in dealing with a delay, the delay by this failure shall not be considered in assessing the new Intended Completion Date.

27 Right to Vary

27.1 The Procuring Entity's Representative with the prior approval of the Procuring Entity may instruct Variations, up to a maximum cumulative amount of ten percent (10%) of the original contract cost.

27.2 Variations shall be valued as follows:

- a. At a lump sum price agreed between the parties;
- b. where appropriate, at rates in this Contract;
- c. in the absence of appropriate rates, the rates in this Contract shall be used as the basis for valuation; or failing which

- d. at appropriate new rates, equal to or lower than current industry rates and to be agreed upon by both parties and approved by the HoPE.

28 Contractor's Right to Claim

If the Contractor incurs cost as a result of any of the events under **GCC** Clause 13, the Contractor shall be entitled to the amount of such cost. If as a result of any of the said events, it is necessary to change the Works, this shall be dealt with as a Variation.

29 Dayworks

29.1 Subject to **GCC** Clause 43 on Variation Order, and if applicable as indicated in the **SCC**, the Dayworks rates in the Contractor's bid shall be used for small additional amounts of work only when the Procuring Entity's Representative has given written instructions in advance for additional work to be paid for in that way.

29.2 All work to be paid for as Dayworks shall be recorded by the Contractor on forms approved by the Procuring Entity's Representative. Each completed form shall be verified and signed by the Procuring Entity's Representative within two days of the work being done.

29.3 The Contractor shall be paid for Dayworks subject to obtaining signed Dayworks forms.

30 Early Warning

30.1 The Procuring Entity's Representative at the earliest opportunity of specific likely future events or circumstances that may adversely affect the quality of the work, increase the Contract Price, or delay the execution of the Works. The Procuring Entity's Representative may require the Contractor to provide an estimate of the expected effect of the future event or circumstance on the Contract Price and Completion Date. The estimate shall be provided by the Contractor as soon as reasonably possible.

30.2 The Contractor shall cooperate with the Procuring Entity's Representative in making and considering proposals for how the effect of such an event or circumstance can be avoided or reduced by anyone involved in the work and in carrying out any resulting instruction of the Procuring Entity's Representative.

31 Program of Work

31.1 Within the time stated in the **SCC**, the Contractor shall submit to the Procuring Entity's Representative for approval a Program of Work showing the general methods, arrangements, order, and timing for all the activities in the Works.

31.2 An update of the Program of Work shall show the actual progress achieved on each activity and the effect of the progress achieved on the timing of the remaining work, including any changes to the sequence of the activities.

31.3 The Contractor shall submit to the Procuring Entity's Representative for approval an updated Program of Work at intervals no longer than the period stated in the **SCC**. If the Contractor does not submit an updated Program of Work within this period, the Procuring Entity's Representative may withhold the amount stated in the **SCC** from the next payment certificate and continue to withhold this amount until the next payment after the date on which the overdue Program of Work has been submitted.

31.4 The Procuring Entity's Representative's approval of the Program of Work shall not alter the Contractor's obligations. The Contractor may revise the Program of Work and submit it to the Procuring Entity's Representative again at any time. A revised Program of Work shall show the effect of any approved Variations.

31.5 When the Program of Work is updated, the Contractor shall provide the Procuring Entity's Representative with an updated cash flow forecast. The cash flow forecast shall include different currencies, as defined in the Contract, converted as necessary using the Contract exchange rates.

31.6 All Variations shall be included in updated Program of Work produced by the Contractor.

32 Management Conferences

32.1 Either the Procuring Entity's Representative or the Contractor may require the other to attend a Management Conference. The Management Conference shall review the plans for remaining work and deal with matters raised in accordance with the early warning procedure.

32.2 The Procuring Entity's Representative shall record the business of Management Conferences and provide copies of the record to those attending the Conference and to the Procuring Entity. The responsibility of the parties for actions to be taken shall be decided by the Procuring Entity's Representative either at the Management Conference or after the Management Conference and stated in writing to all who attended the Conference.

33 Bill of Quantities

33.1 The Bill of Quantities shall contain items of work for the construction, installation, testing, and commissioning of work to be done by the Contractor.

33.2 The Bill of Quantities is used to calculate the Contract Price. The Contractor is paid for the quantity of the work done at the rate in the Bill of Quantities for each item.

33.3 If the final quantity of any work done differs from the quantity in the Bill of Quantities for the particular item and is not more than twenty five percent (25%) of the original quantity, provided the aggregate changes for all items do not exceed ten percent (10%) of the Contract price, the Procuring Entity's Representative shall make the necessary adjustments to allow for the changes subject to applicable laws, rules, and regulations.

33.4 If requested by the Procuring Entity's Representative, the Contractor shall provide the Procuring Entity's Representative with a detailed cost breakdown of any rate in the Bill of Quantities.

34 Instructions, Inspections and Audits

34.1 The Procuring Entity's personnel shall at all reasonable times during construction of the Work be entitled to examine, inspect, measure and test the materials and workmanship, and to check the progress of the construction.

34.2 If the Procuring Entity's Representative instructs the Contractor to carry out a test not specified in the Specification to check whether any work has a defect and the test shows that it does, the Contractor shall pay for the test and any samples. If there is no defect, the test shall be a Compensation Event.

34.3 The Contractor shall permit the Funding Source named in the **SCC** to inspect the Contractor's accounts and records relating to the performance of the Contractor and to have them audited by auditors appointed by the Funding Source, if so, required by the Funding Source.

35 Identifying Defects

The Procuring Entity's Representative shall check the Contractor's work and notify the Contractor of any defects that are found. Such checking shall not affect the Contractor's responsibilities. The Procuring Entity's Representative may instruct the Contractor to search uncover defects and test any work that the Procuring Entity's Representative considers below standards and defective.

36 Cost of Repairs

Loss or damage to the Works or Materials to be incorporated in the Works between the Start Date and the end of the Defects Liability Periods shall be remedied by the Contractor at the Contractor's cost if the loss or damage arises from the Contractor's acts or omissions.

37 Correction of Defects

37.1 The Procuring Entity's Representative shall give notice to the Contractor of any defects before the end of the Defects Liability Period, which is One (1) year from project completion up to final acceptance by the Procuring Entity's Representative.

37.2 Every time notice of a defect is given, the Contractor shall correct the notified defect within the length of time specified in the Procuring Entity's Representative's notice.

37.3 The Contractor shall correct the defects which he notices himself before the end of the Defects Liability Period.

37.4 The Procuring Entity shall certify that all defects have been corrected. If the Procuring Entity considers that correction of a defect is not essential, he can

request the Contractor to submit a quotation for the corresponding reduction in the Contract Price. If the Procuring Entity accepts the quotation, the corresponding change in the SCC is a Variation.

38 Uncorrected Defects

38.1 The Procuring Entity shall give the Contractor at least fourteen (14) days' notice of his intention to use a third party to correct a Defect. If the Contractor does not correct the Defect himself within the period, the Procuring Entity may have the Defect corrected by the third party. The cost of the correction will be deducted from the Contract Price.

38.2 The use of a third party to correct defects that are uncorrected by the Contractor will in no way relieve the Contractor of its liabilities and warranties under the Contract.

39 Advance Payment

39.1 The Procuring Entity shall, upon a written request of the contractor which shall be submitted as a contract document, make an advance payment to the contractor in an amount not exceeding fifteen percent (15%) of the total contract price, to be made in lump sum or, at the most two, installments according to a schedule specified in the **SCC**.

39.2 The advance payment shall be made only upon the submission to and acceptance by the Procuring Entity of an irrevocable standby letter of credit of equivalent value from a commercial bank, a bank guarantee or a surety bond callable upon demand, issued by a surety or insurance company duly licensed by the Insurance Commission and confirmed by the Procuring Entity.

39.3 The advance payment shall be repaid by the Contractor by an amount equal to the percentage of the total contract price used for the advance payment.

39.4 The contractor may reduce his standby letter of credit or guarantee instrument by the amounts refunded by the Monthly Certificates in the advance payment.

39.5 The Procuring Entity will provide an Advance Payment on the Contract Price as stipulated in the Conditions of Contract, subject to the maximum amount stated in **SCC** Clause 39.1.

40 Progress Payments

40.1 The Contractor may submit a request for payment for Work accomplished. Such request for payment shall be verified and certified by the Procuring Entity's Representative/Project Engineer. Except as otherwise stipulated in the **SCC**, materials and equipment delivered on the site but not completely put in place shall not be included for payment.

40.2 The Procuring Entity shall deduct the following from the certified gross amounts to be paid to the contractor as progress payment:

- a. Cumulative value of the work previously certified and paid for.
- b. Portion of the advance payment to be recouped for the month.
- c. Retention money in accordance with the condition of contract.
- d. Amount to cover third party liabilities.
- e. Amount to cover uncorrected discovered defects in the works.

40.3 Payments shall be adjusted by deducting therefrom the amounts for advance payments and retention. The Procuring Entity shall pay the Contractor the amounts certified by the Procuring Entity's Representative within twenty-eight (28) days from the date each certificate was issued. No payment of interest for delayed payments and adjustments shall be made by the Procuring Entity.

40.4 The first progress payment may be paid by the Procuring Entity to the Contractor provided that at least twenty percent (20%) of the work has been accomplished as certified by the Procuring Entity's Representative.

40.5 Items of the Works for which a price of "0" (zero) has been entered will not be paid for by the Procuring Entity and shall be deemed covered by other rates and prices in the Contract.

41 Payment Certificates

41.1 The Contractor shall submit to the Procuring Entity's Representative monthly statements of the estimated value of the work executed less the cumulative amount certified previously.

41.2 The Procuring Entity's Representative shall check the Contractor's monthly statement and certify the amount to be paid to the Contractor.

41.3 The value of Work executed shall:

- a. be determined by the Procuring Entity's Representative;
- b. comprise the value of the quantities of the items in the Bill of Quantities completed; and
- c. include the valuations of approved variations.

41.4 The Procuring Entity's Representative may exclude any item certified in a previous certificate or reduce the proportion of any item previously certified in any certificate in the light of later information.

42 Retention

42.1 The Procuring Entity shall retain from each payment due to the Contractor an amount equal to a percentage thereof using the rate as specified in GCC Sub-Clause 42.2.

42.2 Progress payments are subject to retention of ten percent (10%), referred to as the “retention money.” Such retention shall be based on the total amount due to the Contractor prior to any deduction and shall be retained from every progress payment until fifty percent (50%) of the value of Works, as determined by the Procuring Entity, are completed. If, after fifty percent (50%) completion, the Work is satisfactorily done and on schedule, no additional retention shall be made; otherwise, the ten percent (10%) retention shall again be imposed using the rate specified therefor.

42.3 The total “retention money” shall be due for release upon final acceptance of the Works. The Contractor may, however, request the substitution of the retention money for each progress billing with irrevocable standby letters of credit from a commercial bank, bank guarantees or surety bonds callable on demand, of amounts equivalent to the retention money substituted for and acceptable to the Procuring Entity, provided that the project is on schedule and is satisfactorily undertaken. Otherwise, the ten (10%) percent retention shall be made. Said irrevocable standby letters of credit, bank guarantees and/or surety bonds, to be posted in favor of the Government shall be valid for a duration to be determined by the concerned implementing office/agency or Procuring Entity and will answer for the purpose for which the ten (10%) percent retention is intended, *i.e.*, to cover uncorrected discovered defects and third party liabilities.

42.4 On completion of the whole Works, the Contractor may substitute retention money with an “on demand” Bank guarantee in a form acceptable to the Procuring Entity.

43 Variation Orders

43.1 Variation Orders may be issued by the Procuring Entity to cover any increase/decrease in quantities, including the introduction of new work items that are not included in the original contract or reclassification of work items that are either due to change of plans, design or alignment to suit actual field conditions resulting in disparity between the preconstruction plans used for purposes of bidding and the “as staked plans” or construction drawings prepared after a joint survey by the Contractor and the Procuring Entity after award of the contract, provided that the cumulative amount of the Variation Order does not exceed ten percent (10%) of the original project cost. The addition/deletion of Works should be within the general scope of the project as bid and awarded. The scope of works shall not be reduced so as to accommodate a positive Variation Order. A Variation Order may either be in the form of a Change Order or Extra Work Order.

43.2 A Change Order may be issued by the Procuring Entity to cover any increase/decrease in quantities of original Work items in the contract.

43.3 An Extra Work Order may be issued by the Procuring Entity to cover the introduction of new work necessary for the completion, improvement or protection of the project which were not included as items of Work in the original contract, such as, where there are subsurface or latent physical

conditions at the site differing materially from those indicated in the contract, or where there are duly unknown physical conditions at the site of an unusual nature differing materially from those ordinarily encountered and generally recognized as inherent in the Work or character provided for in the contract.

43.4 Any cumulative Variation Order beyond ten percent (10%) shall be subject of another contract to be bid out if the works are separable from the original contract. In exceptional cases where it is urgently necessary to complete the original scope of work, the HoPE may authorize a positive Variation Order go beyond ten percent (10%) but not more than twenty percent (20%) of the original contract price, subject to the guidelines to be determined by the GPPB: *Provided, however,* That appropriate sanctions shall be imposed on the designer, consultant or official responsible for the original detailed engineering design which failed to consider the Variation Order beyond ten percent (10%).

43.5 In claiming for any Variation Order, the Contractor shall, within seven (7) calendar days after such work has been commenced or after the circumstances leading to such condition(s) leading to the extra cost, and within twenty-eight (28) calendar days deliver a written communication giving full and detailed particulars of any extra cost in order that it may be investigated at that time. Failure to provide either of such notices in the time stipulated shall constitute a waiver by the contractor for any claim. The preparation and submission of Variation Orders are as follows:

- a. If the Procuring Entity's representative/Project Engineer believes that a Change Order or Extra Work Order should be issued, he shall prepare the proposed Order accompanied with the notices submitted by the Contractor, the plans therefore, his computations as to the quantities of the additional works involved per item indicating the specific stations where such works are needed, the date of his inspections and investigations thereon, and the log book thereof, and a detailed estimate of the unit cost of such items of work, together with his justifications for the need of such Change Order or Extra Work Order, and shall submit the same to the HoPE for approval.
- b. The HoPE or his duly authorized representative, upon receipt of the proposed Change Order or Extra Work Order shall immediately instruct the appropriate technical staff or office of the Procuring Entity to conduct an on-the-spot investigation to verify the need for the Work to be prosecuted and to review the proposed plan, and prices of the work involved.
- c. The technical staff or appropriate office of the Procuring Entity shall submit a report of their findings and recommendations, together with the supporting documents, to the Head of Procuring Entity or his duly authorized representative for consideration.
- d. The HoPE or his duly authorized representative, acting upon the recommendation of the technical staff or appropriate office, shall

approve the Change Order or Extra Work Order after being satisfied that the same is justified, necessary, and in order.

- e. The timeframe for the processing of Variation Orders from the preparation up to the approval by the Procuring Entity concerned shall not exceed thirty (30) calendar days.

44 Contract Completion

Once the project reaches an accomplishment of ninety five (95%) of the total contract amount, the Procuring Entity may create an inspectorate team to make preliminary inspection and submit a punch-list to the Contractor in preparation for the final turnover of the project. Said punch-list will contain, among others, the remaining Works, Work deficiencies for necessary corrections, and the specific duration/time to fully complete the project considering the approved remaining contract time. This, however, shall not preclude the claim of the Procuring Entity for liquidated damages.

45 Suspension of Work

45.1 The Procuring Entity shall have the authority to suspend the work wholly or partly by written order for such period as may be deemed necessary, due to *force majeure* or any fortuitous events or for failure on the part of the Contractor to correct bad conditions which are unsafe for workers or for the general public, to carry out valid orders given by the Procuring Entity or to perform any provisions of the contract, or due to adjustment of plans to suit field conditions as found necessary during construction. The Contractor shall immediately comply with such order to suspend the work wholly or partly.

45.2 The Contractor or its duly authorized representative shall have the right to suspend work operation on any or all projects/activities along the critical path of activities after fifteen (15) calendar days from date of receipt of written notice from the Contractor to the district engineer/regional director/consultant or equivalent official, as the case may be, due to the following:

- a. There exist right-of-way problems which prohibit the Contractor from performing work in accordance with the approved construction schedule.
- b. Requisite construction plans which must be owner-furnished are not issued to the contractor precluding any work called for by such plans.
- c. Peace and order conditions make it extremely dangerous, if not possible, to work. However, this condition must be certified in writing by the Philippine National Police (PNP) station which has responsibility over the affected area and confirmed by the Department of Interior and Local Government (DILG) Regional Director.

- d. There is failure on the part of the Procuring Entity to deliver government-furnished materials and equipment as stipulated in the contract.
- e. Delay in the payment of Contractor's claim for progress billing beyond forty-five (45) calendar days from the time the Contractor's claim has been certified to by the procuring entity's authorized representative that the documents are complete unless there are justifiable reasons thereof which shall be communicated in writing to the Contractor.

45.3 In case of total suspension, or suspension of activities along the critical path, which is not due to any fault of the Contractor, the elapsed time between the effectivity of the order suspending operation and the order to resume work shall be allowed the Contractor by adjusting the contract time accordingly.

46 Payment on Termination

46.1 If the Contract is terminated because of a fundamental breach of Contract by the Contractor, the Procuring Entity's Representative shall issue a certificate for the value of the work done and Materials ordered less advance payments received up to the date of the issue of the certificate and less the percentage to apply to the value of the work not completed, as indicated in the SCC. Additional Liquidated Damages shall not apply. If the total amount due to the Procuring Entity exceeds any payment due to the Contractor, the difference shall be a debt payable to the Procuring Entity.

46.2 If the Contract is terminated for the Procuring Entity's convenience or because of a fundamental breach of Contract by the Procuring Entity, the Procuring Entity's Representative shall issue a certificate for the value of the work done, Materials ordered, the reasonable cost of removal of Equipment, repatriation of the Contractor's personnel employed solely on the Works, and the Contractor's costs of protecting and securing the Works, and less advance payments received up to the date of the certificate.

46.3 The net balance due shall be paid or repaid within twenty-eight (28) days from the notice of termination.

46.4 If the Contractor has terminated the Contract under GCC Clauses 17 or 18, the Procuring Entity shall promptly return the Performance Security to the Contractor.

47 Extension of Contract Time

47.1 Should the amount of additional work of any kind or other special circumstances of any kind whatsoever occur such as to fairly entitle the contractor to an extension of contract time, the Procuring Entity shall determine the amount of such extension; provided that the Procuring Entity is not bound to take into account any claim for an extension of time unless the Contractor has, prior to the expiration of the contract time and within thirty (30) calendar days after such work has been commenced or after the

circumstances leading to such claim have arisen, delivered to the Procuring Entity notices in order that it could have investigated them at that time. Failure to provide such notice shall constitute a waiver by the Contractor of any claim. Upon receipt of full and detailed particulars, the Procuring Entity shall examine the facts and extent of the delay and shall extend the contract time completing the contract work when, in the Procuring Entity's opinion, the findings of facts justify an extension.

47.2 No extension of contract time shall be granted the Contractor due to (a) ordinary unfavorable weather conditions and (b) inexcusable failure or negligence of Contractor to provide the required equipment, supplies or materials.

47.3 Extension of contract time may be granted only when the affected activities fall within the critical path of the PERT/CPM network.

47.4 No extension of contract time shall be granted when the reason given to support the request for extension was already considered in the determination of the original contract time during the conduct of detailed engineering and in the preparation of the contract documents as agreed upon by the parties before contract perfection.

47.5 Extension of contract time shall be granted for rainy/unworkable days considered unfavorable for the prosecution of the works at the site, based on the actual conditions obtained at the site, in excess of the number of rainy/unworkable days pre-determined by the Procuring Entity in relation to the original contract time during the conduct of detailed engineering and in the preparation of the contract documents as agreed upon by the parties before contract perfection, and/or for equivalent period of delay due to major calamities such as exceptionally destructive typhoons, floods and earthquakes, and epidemics, and for causes such as non-delivery on time of materials, working drawings, or written information to be furnished by the Procuring Entity, non-acquisition of permit to enter private properties or non-execution of deed of sale or donation within the right-of-way resulting in complete paralyzation of construction activities, and other meritorious causes as determined by the Procuring Entity's Representative and approved by the HoPE. Shortage of construction materials, general labor strikes, and peace and order problems that disrupt construction operations through no fault of the Contractor may be considered as additional grounds for extension of contract time provided they are publicly felt and certified by appropriate government agencies such as DTI, DOLE, DILG, and DND, among others. The written consent of bondsmen must be attached to any request of the Contractor for extension of contract time and submitted to the Procuring Entity for consideration and the validity of the Performance Security shall be correspondingly extended.

48 Price Adjustment

Except for extraordinary circumstances as determined by NEDA and approved by the GPPB, no price escalation shall be allowed. Nevertheless, in cases where the cost of

the awarded contract is affected by any applicable new laws, ordinances, regulations, or other acts of the GoP, promulgated after the date of bid opening, a contract price adjustment shall be made or appropriate relief shall be applied on a no loss-no gain basis.

49 Completion

The Contractor shall request the Procuring Entity's Representative to issue a certificate of Completion of the Works, and the Procuring Entity's Representative will do so upon deciding that the work is completed.

50 Taking Over

The Procuring Entity shall take over the Site and the Works within seven (7) days from the date the Procuring Entity's Representative issues a certificate of Completion.

51 Operating and Maintenance Manuals

51.1 If "as built" Drawings and/or operating and maintenance manuals are required, the Contractor shall supply them by the dates stated in the SCC.

51.2 If the Contractor does not supply the Drawings and/or manuals by the dates stated in the SCC, or they do not receive the Procuring Entity's Representative's approval, the Procuring Entity's Representative shall withhold the amount stated in the SCC from payments due to the Contractor.

Section V. Special Conditions of Contract

Special Conditions of Contract

GCC Clause	
1.17	The Intended Completion Date is <i>[Insert date]</i> . <i>NOTE: The contract duration shall be reckoned from the start date and not from contract effectivity date.</i>
1.22	The Procuring Entity is Bantayan Island Electric Cooperative, Inc. (BANELCO), Balintawak Bantigue, Bantayan Cebu.
1.23	The Procuring Entity’s Representative is <i>Engr. Lee D. Rivera.</i>
1.24	The Site is located at <i>Moamboc, Sulangan and Hilotongan, Bantayan, Cebu.</i>
1.28	The Start Date is <i>[Insert date]</i> . <i>NOTE: The start date shall be the date of receipt of the Notice to Proceed.</i>
1.31	The Works consist of Supply, Delivery and Installation of On-shore Cable Protection, Primary Metering, Line Conversion and Extension.
2.2	<i>If different dates are specified for completion of the Works by section (“sectional completion”), these dates should be listed here</i>
5.1	The Procuring Entity shall give possession of all parts of the Site to the Contractor <i>[insert date]</i> .
6.5	The Contractor shall employ the following Key Personnel: <i>[List key personnel by name and designation]</i> <i>NOTE: The names of the Key Personnel and their designation shall be filled out by winning contractor prior to contract signing.</i>
7.4(c)	No further instructions.
7.7	No further instructions.
8.1	No further instructions.
10	The site investigation reports are: <i>[list here or state none]</i>
12.3	No further instructions.
12.5	<i>One (1) year from project completion up to final acceptance or the defects liability period.</i>

13	<i>State here “No additional provision.” or, if the Contractor is a joint venture, “All partners to the joint venture shall be jointly and severally liable to the Procuring Entity.”</i>
18.3(h)(i)	No further instructions.
21.2	The Arbiter is: <i>[Insert name]</i> <i>[Insert address]</i>
29.1	Dayworks are applicable at the rate shown in the Contractor’s original Bid.
31.1	The Contractor shall submit the Program of Work to the Procuring Entity’s Representative within <i>[5]</i> days of delivery of the Notice of Award.
31.3	The period between Program of Work updates is <i>[7]</i> days. The amount to be withheld for late submission of an updated Program of Work is <i>[insert amount]</i> .
34.3	The Funding Source is the <i>2024 LFP-TEP Subsidy</i> .
39.1	The amount of the advance payment is <i>[insert amount as percentage of the Contract Price and schedule of payment]</i>
40.1	No further instructions.
51.1	The date by which operating and maintenance manuals are required is <i>[date]</i> . The date by which “as built” drawings are required is <i>[date]</i> .
51.2	The amount to be withheld for failing to produce “as built” drawings and/or operating and maintenance manuals by the date required is <i>[amount in local currency]</i> .

Section VI. Specifications & Drawings

Note:

All Specifications will strictly follow the NEA Standards for Construction of Distribution Lines

PROJECT LOCATION MAP



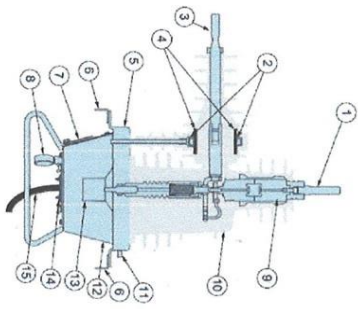

Cross section of PMSet U-Series

1. X-side terminal 2
2. Current transformer
3. I-side terminal
4. Capacitive voltage transformer
5. Lid
6. Lightning arrester brackets
7. On/Off indicator
8. Manual trip ring
9. Vacuum interrupter
10. Epoxy bushing
11. Earthing point
12. Tank
13. Magnetic actuator
14. SCEM card
15. Control cable

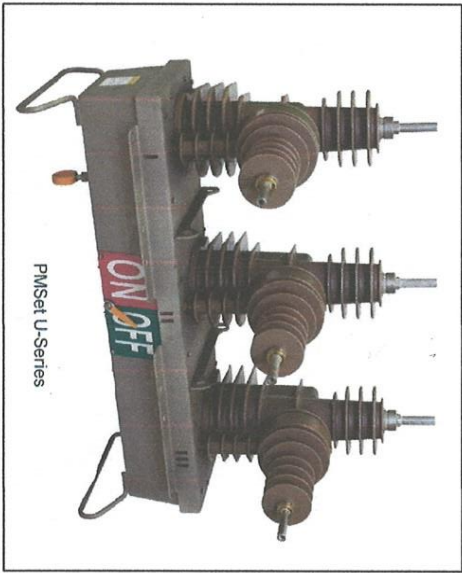
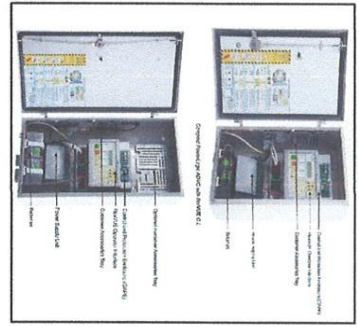

PMSet U-Series RECLOSER SPECIFICATION

Description	Specification
Ratings	
PMSet U-Series Range	15 kV - 27 kV
	12.5 kA - 12.5 kA
Rated Maximum Voltage	15.5 kV - 27 kV
Rated Continuous Current	630 A - 630 A
Fault Make Capacity (rms)	12.5 kA - 12.5 kA
Fault Make Capacity (Peak)	31.5 kA - 31.5 kA
Power Operating Time (Close/Open)	0.1/0.05 s - 0.1/0.05 s
Mechanical Operations	10,000 - 10,000
Rated Full Load Operations	10,000 - 10,000
Short time Current	12.5 kA - 12.5 kA
Breaking Capacity	
Mainly Active (0.17 pf)	630 A - 630 A
Fault Break Capacity	12.5 kA - 12.5 kA
Cable Charging	25 A - 22 A
Line Charging	22 A - 22 A
Lighting Impulse Withstand Level	
Phase to Earth	110 kV - 125 kV
Across Interrupter	110 kV - 125 kV
Power Frequency Withstand Voltage	
Phase to Earth	50 kV - 60 kV
Across Interrupter	50 kV - 60 kV
Service Conditions	
Ambient Temperature (°C)	-40...50 -40...50
Ambient Temperature (°F)	-40...122 -40...122
Radiation (Max.)	1.1 kW/m ² - 1.1 kW/m ²
Humidity	0...100% - 0...100%
Altitude meters (Max.)¹⁾	3000 - 3000
Altitude feet (Max.)²⁾	9840 - 9840
Net Weights	
Circuit breaker with pole mount bracket (kg/ lbs)	118/261 - 118/261
Control cabinet with control cable (kg/lbs)	41/90 - 41/90
Gross Weight of crane (kg/lbs)	263/580 - 263/580
Crate Dimensions	
Width (mm/in.)	990/37.8 - 990/37.8
Depth (mm/in.)	1020/40.5 - 1020/40.2
Height (mm/in.)	1180/45.7 - 1180/45.7

PREPARED BY:
RADIANE X. DUARTE
 MANAGER, SYSTEM PLANNING & LINE CONSTRUCTION DIVISION

NOTED BY:
ENGR. RONALD D. ALOYAN
 TSD MANAGER

APPROVED BY:
ENGR. LEE D. RIVERA
 GENERAL MANAGER

BANTAYAN ISLAND ELECTRIC COOPERATIVE, INC.
 Balintawak, Bantigue, Bantayan, Cebu
 SUBMARINE CABLE SENDING POINT RECLOSER SPECIFICATION SINGLE
 PHASE U-SERIES SITTO MOAMBICC, BRAWAGAY SULANGAN, BANTAYAN, CEBU

BANTAYAN ISLAND ELECTRIC COOPERATIVE, INC.
(BANE/CO)
Baitanwak, Bantigue, Bantayan, Cebu

October 21, 2024

Project Description: Construction of Sending Point of Submarine Cable in Sitio Moamboc Barangay Sulangan, Bantayan, Cebu

Bill of Materials:

MATERIALS DESCRIPTION	PROJECT REQUIREMENTS
Bolt, Double Aiming, 5/8" x 16"	11 pieces
Bolt, Double Aiming, 5/8" x 18"	9 pieces
Bolt, Double Aiming, 5/8" x 24"	10 pieces
Bolt, Oval Eye, 5/8" x 9"	1 piece
Bolt, Machine, 1/2" x 6"	12 pieces
Bolt, Machine, 5/8" x 6"	8 pieces
Bolt, Machine, 5/8" x 8"	3 pieces
Bolt, Machine, 5/8" x 14"	6 pieces
Bolt, Machine, 5/8" x 18"	4 pieces
Bolt, Thimble Eye, 5/8" x 10", Angle Type	4 pieces
Bolt, Thimble Eye, 5/8" x 10", Angle Type	4 pieces
Bracket, Mounting for Cutout and Arrestor	6 each
Bracket, Mounting for Transformer Pole	1 piece
Bracket, Mounting for Transformer Pole	2 pieces
Clamp, Hot Line, #2 - #2/0 ACSR Main to #2 - #2/0	3 pieces
Clamp, Anchor Rod Bonding, Single Eye	10 pieces
Clamp, Loop Deadend, #2/0 ACSR	4 pieces
Clamp, Deadend Strain, #1/0 ACSR	12 pieces
Clamp, Pole, Mounting Adapter, (8 - 9), Type CA	20 pieces
Clamp, Deadend Grip, 3/8" Spacing without Steel	4 pieces
Conductor, Insulated Three Wire, Non Shielded HDPEXLPE ANIG #1/0	362 meters
Conductor, Insulated ACSR #2 AWG 6/1 (600V)	30 meters
Conductor, Insulated Copper Wire, ACSR #6	15 meters
Conductor, Insulated Copper Wire, ACSR #6	30 meters
Connector, Compression, YHO 150, #3 - #1/0 ACSR Run To #6 - #2	63 pieces
Connector, Compression, YHD 300, #1/0 - #2/0 ACSR Run To #10 - #2/0	35 pieces
Connector, Ground Rod (Clamp) for 5/8" Steel Rod	2 pieces
Fuse Cut-out & Arrestor Combination, 15kv, Class 200	7 sets
Lightning Arrestor, 9-10 KV, Polymer	12 pieces
Insulator, Spool, 3", ANSI, Class 55 - 5	12 pieces
Pin, Crossarm, Steel, F-58 x 14, ZSNV	12 pieces
Pin, Crossarm, Steel, F-58 x 14, ZSNV	12 pieces
Pin, Crossarm, Steel, F-58 x 14, ZSNV	12 pieces
Pin, Crossarm, Steel, F-58 x 14, ZSNV	12 pieces
Link, Fuse, Universal Bottom Head, Type K, 20 Amperes	3 pieces
Link, Fuse, Universal Bottom Head, Type K, 20 Amperes	3 pieces
Link, Fuse, Universal Bottom Head, Type K, 20 Amperes	3 pieces
Link, Fuse, Universal Bottom Head, Type K, 20 Amperes	3 pieces
Null, Lock, M Type, 5/8"	12 pieces
Null, Thimble Eye, 5/8"	71 pieces
Pin, Pole Top, Channel, 1" Thread, 25" Long	4 pieces
Rod, Anchor, Threaded, Single Eye, 3/4" x 8"	4 pieces
Rod, Anchor, Threaded, Double Eye, 1" x 8"	2 pieces
Rod, Ground Steel, Galvanized, 5/8" x 10"	2 pieces
Transformer, Pole Type, Conventional, Silicon, 10 KVA	1 unit
Wire, Insulated, 14 mm	36 meters
Washer, Square, 1/2" Dia, 1/4" Thick, 2.144" x 3.115", 13/16" Diameter Hole	122 pieces
Washer, Square, 1/2" Dia, 1/4" Thick, 2.144" x 3.115", 13/16" Diameter Hole	122 pieces
Wire, Guy, Steel, 3/8" 7 Strand	162 meters
Current Transformer, 10.5, 15 kv, Extended Range	3 units
Potential Transformer, 15 kv, 8400/120V, 70-1	3 units
Disconnecting Switch, 15 kv, 600A	3 units

PREPARED BY: 
RADNIE A. DUARTE
MANAGER, SYSTEM PLANNING & LINE CONSTRUCTION DIVISION

NOTED BY: 
ENGR RONALD D. ALOYAN
TSD MANAGER

APPROVED BY: 
ENGR. LEE D. RIVERA
GENERAL MANAGER

 **BANTAYAN ISLAND ELECTRIC COOPERATIVE, INC.**
Baitanwak, Bantigue, Bantayan, Cebu

BILL OF MATERIALS OF SUBMARINE CABLE SENDING POINT IN SITIO MOAMBOC, BARANGAY, SULANGAN, BANTAYAN, CEBU

Meter Box, 24"x27"x12"	1 piece
Meter Test Block	1 piece
Meter KVH, 3 Phase, Class 20, 120V480V, Form 48A Electronic Energy KVARRH	1 piece
3 Phase Reducer, 600A	1 unit
Stranded Copper Wire, #12 (black)	60 meters
Stranded Copper Wire, #12 (red)	30 meters
Stranded Copper Wire, #12 (yellow)	30 meters
Stranded Copper Wire, #12 (blue)	30 meters
Terminal Lug, #6 Single Hole	10 pieces
Terminal Lug, Long Barrel, #30, Single Hole	10 pieces
Terminal Lug, Long Barrel, #30, Double Hole	10 pieces
Stem Connector, Pigtail, #30	12 pieces
Outlet Cover (Source Side)	3 pieces
Outlet Cover (Load Side)	3 pieces
Transformer Bushing Cover	8 pieces
Lightning Arrestor Cover	10 pieces
Non-Metallic, Liquidtight, Flexible Conduit #1"	30 meters
Liquidtight Conduit Fitting #1"	16 pieces

Concrete/Steel Materials

Pole, Steel, 40" Base-4.0 mm, 86 Micron, 1280 lbs (Minimum Load Break)	2 pieces
Block, Anchor, Concrete	9 pieces
Crossarm, Steel, 3" x 4" x 10", 3.0 mm	16 pieces
Crossarm, Steel, 3" x 4" x 10", 3.0 mm	16 pieces

Bill of Materials for Fencing

Gravel	20 cubic
Sand	30 cubic
Cement	50 sacks
Deform Bar, 8mm	54 pieces
Deform Bar, 10mm	20 pieces
Deform Bar, 12mm	54 pieces
G.I. Pipe, 2" dia, sch. 40	2 pieces
G.I. Pipe, 1 1/2" dia, sch. 40	2 pieces
Tie Wire #16	50 lbs.
Steel Meshing	2 pieces
Fat Bar, 1 1/2" x 20"	2 pieces
Concrete Primer & Sealer White	10 pails.
Paint Gloss Latex (Green)	10 pails.
Concrete Hollow Blocks, 4"	500 pieces

Equipment and Neutral Grounding Materials

Bare Copper, #2/0	12 meters
Grounding Copper Rod, 5/8" x 1/8"	7 pieces
Grounding Copper Wire, #4/0 AWG	64 meters
Grounding Copper Wire, #2 AWG	21 meters
Terminal Lug for #2/0 Insulated Copper Wire	12 pieces

Prepared by:
Radnie A. Duarte
Manager, SP-LEC Division

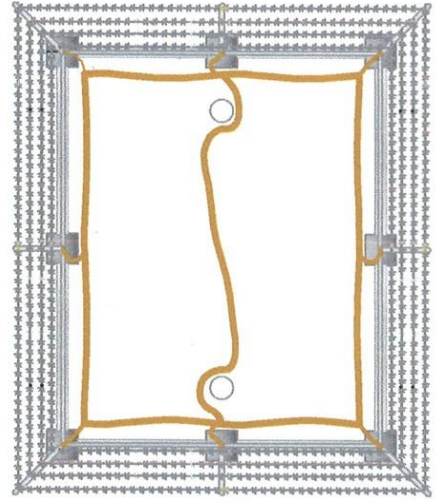

TOP VIEW

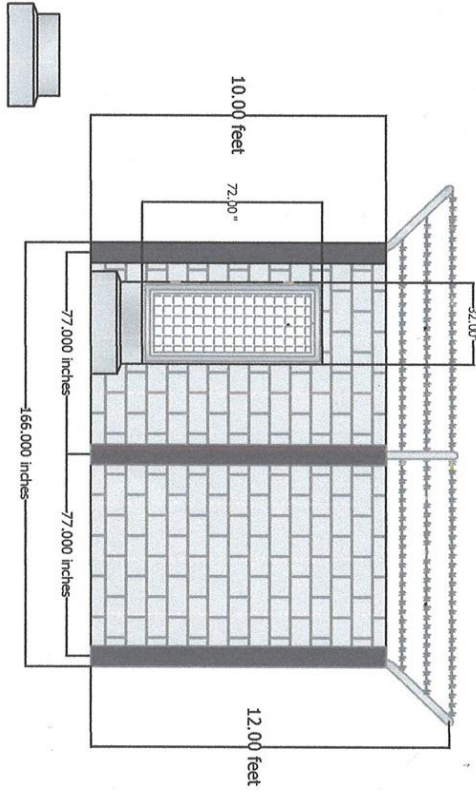
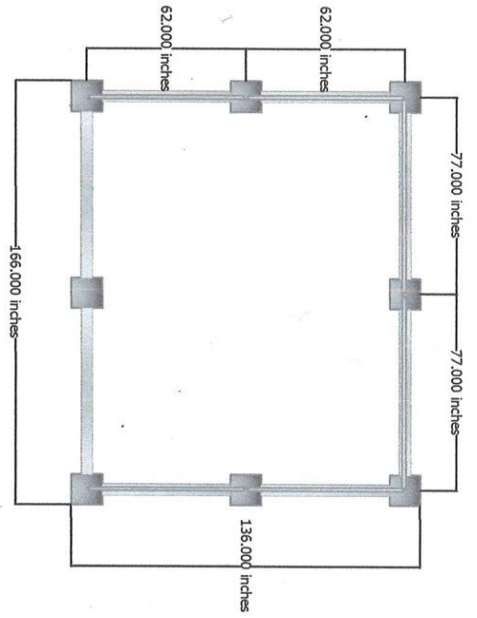

FRONT VIEW

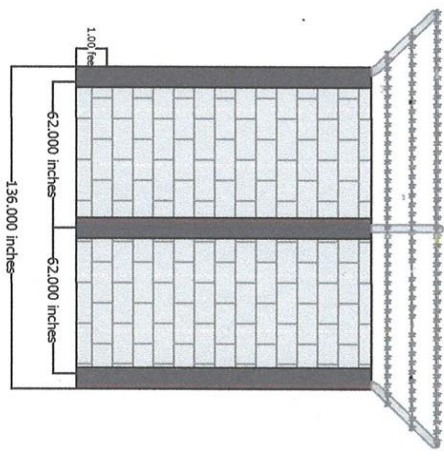

SIDE VIEW

PREPARED BY: *[Signature]*
RADNITE A. DUARTE
 MANAGER, SYSTEM PLANNING & LINE CONSTRUCTION DIVISION

NOTED BY: *[Signature]*
ENGR RONALD D. ALOYAN
 TSD MANAGER

APPROVED BY: *[Signature]*
ENGR. LEE D. RIVERA
 GENERAL MANAGER

 **BANTAYAN ISLAND ELECTRIC COOPERATIVE, INC.**
 Balintawak, Bantigue, Bantayan, Cebu
 PROPOSED H-FRAME STRUCTURE OF SUBMARINE CABLE SENDING POINT IN
 SITTO MOAMBOC, BARANGAY, SULANGAN, BANTAYAN, CEBU

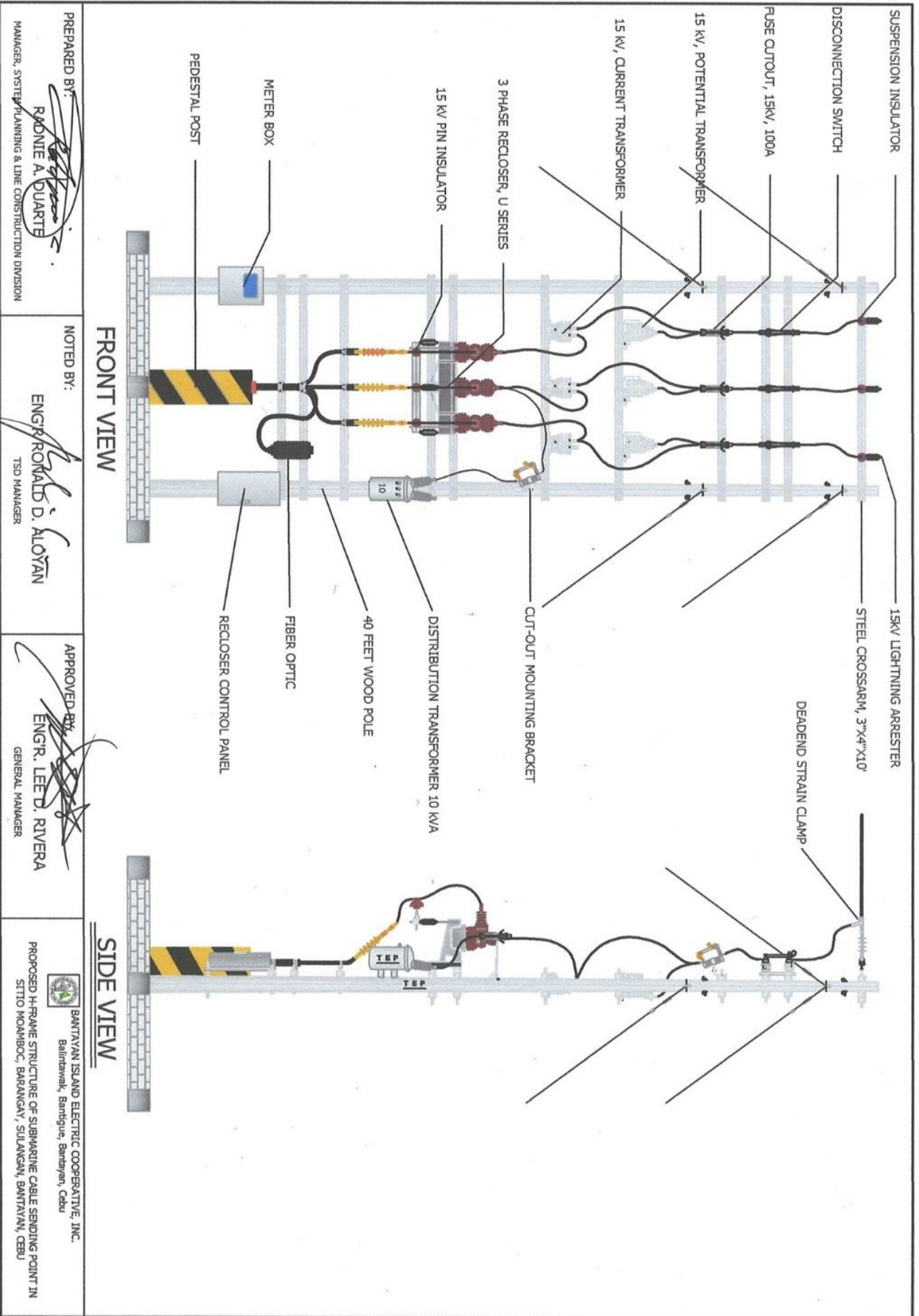

PREPARED BY: *[Signature]*
RADNIE A. DUARTE
 MANAGER, SYSTEM PLANNING & LINE CONSTRUCTION DIVISION

NOTED BY: *[Signature]*
ENGR. RONALD D. ALOYAN
 TSD MANAGER

APPROVED BY: *[Signature]*
ENGR. LEEDY RIVERA
 GENERAL MANAGER

 **BANTAYAN ISLAND ELECTRIC COOPERATIVE, INC.**
 Balintawak, Bantigue, Bantayan, Cebu
 PROPOSED H-FRAME STRUCTURE OF SUBMARINE CABLE SENDING POINT IN
 SITIO MOAMBOC, BARRANGAY, SULANGAY, BANTAYAN, CEBU

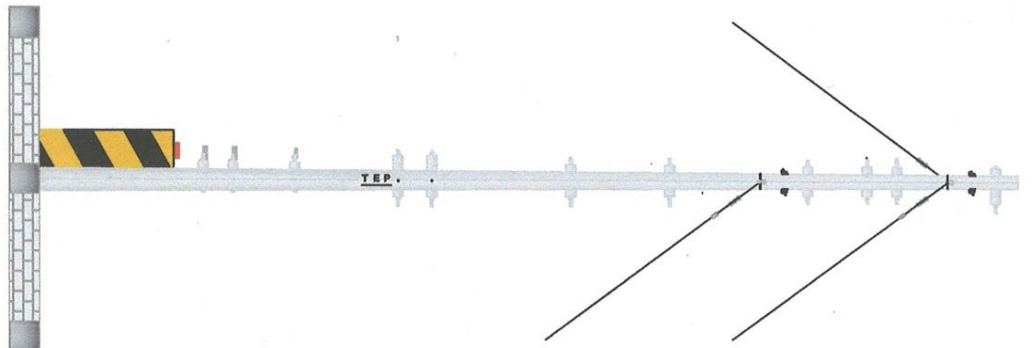
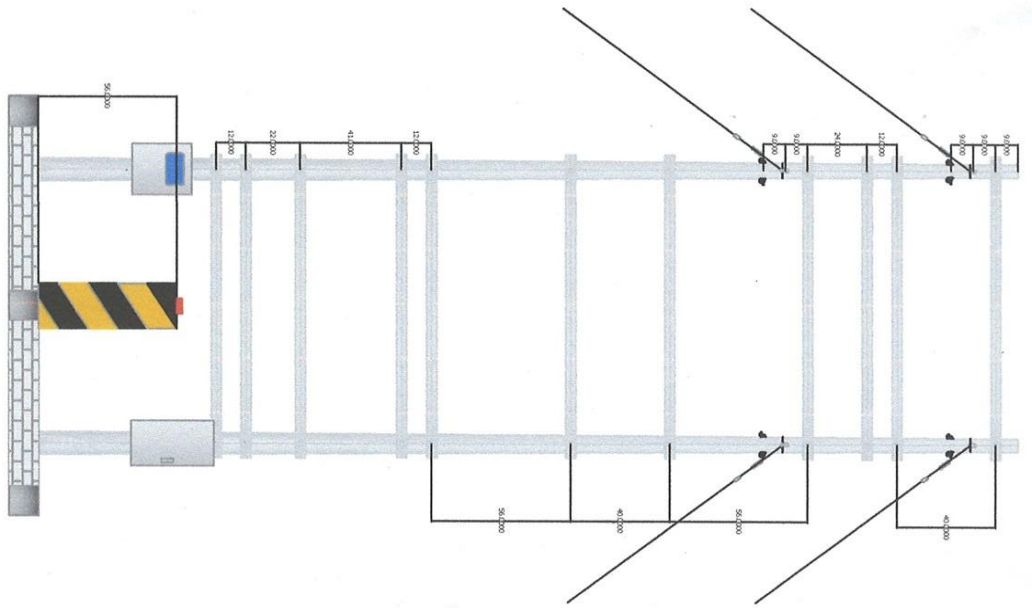

PREPARED BY:

KRONTE A. DUARTE
 MANAGER, SYSTEM PLANNING & LINE CONSTRUCTION DIVISION

NOTED BY:

ENGR. RONALD D. ALOYAN
 TSD MANAGER

APPROVED BY:

ENGR. LEE D. RIVERA
 GENERAL MANAGER

BANTAYAN ISLAND ELECTRIC COOPERATIVE, INC.
 Balintawak, Bantigue, Bantayan, Cebu
 PROPOSED H-FRAME STRUCTURE OF SUBMARINE CABLE SENDING POINT IN
 SITIO MOAMBIC, BARANGAN, SULANGAN, BANTAYAN, CEBU

PMSet W-Series RECLOSER SPECIFICATION

Description	Specification
Ratings	
Rated Maximum Voltage	24 kV
Rated Nominal Voltage (phase to ground)	21 kV
Rated Continuous Current	400A
Fault Make Capacity (rms)	6KA
Fault Make Capacity (Peak)	15KA
Power Operating Time (Close/Open)	0.1/0.05 s
Mechanical Operations	
Rated Full Load Operations	10,000
Short time Current	6 KA
Breaking Capacity	
Mainly Active (0.7 pf)	400A
Fault Break Capacity	6 kA
Cable Charging	25 A
Line Charging	5 A
Transformer magnetizing	22 A
Lightning Impulse Withstand Level	
Phase to Earth	60 kV
Across Interrupter	60 kV
Power Frequency Withstand Voltage	
Phase to Earth	60 kV
Across Interrupter	60 kV
Service Conditions	
Ambient Temperature ⁽¹⁾ (°C)	-30...50
Ambient Temperature ⁽²⁾ (°F)	-22...122
Radiation (Max.)	1.1 kW/m ²
Humidity	0...100%
Altitude meters (Max.) ³	3000
Altitude feet (Max.) ³	9840
Net Weights	
Circuit breaker with pole mount bracket (kg/lbs)	79/165
Control cubicle with control cable (kg/lbs)	41/90
Crate Dimensions	
Width (mm/in.)	1150/45.3
Depth (mm/in.)	1150/45.3
Height (mm/in.)	57/22.4

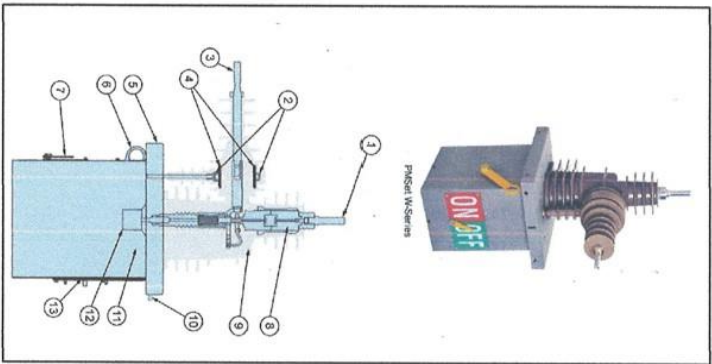
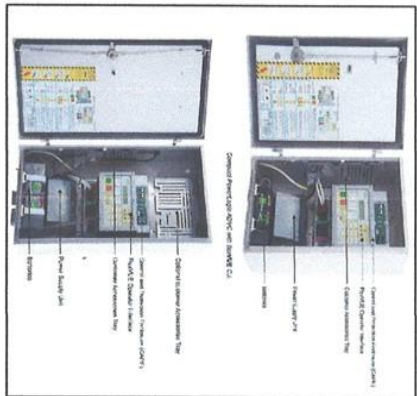

- Cross section of PMSet W-Series**
- X-side terminal 2
 - Current transformer
 - I-side terminal
 - Capacitive voltage transformer
 - Stainless steel or mild steel lid
 - Manual trip ring
 - On/Off indicator
 - Vacuum interrupter
 - Epoxy bushing
 - Earring point
 - Stainless steel or mildsteel tank
 - Magnetic actuator
 - SCEM card

PREPARED BY:
RAMON A. DUARTE
 MANAGER, SYSTEM PLANNING & LINE CONSTRUCTION DIVISION

NOTED BY:
ENGR RONALD D. ALOYAN
 TSD MANAGER

APPROVED BY:
ENGR. LEE D. RIVERA
 GENERAL MANAGER

BANTAYAN ISLAND ELECTRIC COOPERATIVE, INC.
 Baitanewak, Bantigue, Bantayan, Cebu

SUBMARINE CABLE RECEIVING POINT RECLOSER SPECIFICATION SINGLE PHASE W-SERIES SITTO BAYABAS, BARANGAY HILTONGAN, BANTAYAN, CEBU

BANTAYAN ISLAND ELECTRIC COOPERATIVE, INC.
(BANELCO)
Baintawak, Bantigue, Bantayan, Cebu

October 21, 2024

Project Description: Construction of Receiving Point of Submarine Cable in Puruk Bayabas Barangay Hilotongan, Bantayan, C.

Bill of Materials:

MATERIALS DESCRIPTION	PROJECT REQUIREMENTS
Bolt, Double Armring, 5/8" x 18"	9 pieces
Bolt, Double Armring, 5/8" x 18"	14 pieces
Bolt, Double Armring, 5/8" x 22"	8 pieces
Bolt, Oval Eye, 5/8" x 9"	2 pieces
Bolt, Machine, 1/2" x 6"	18 pieces
Bolt, Machine, 5/8" x 8"	5 pieces
Bolt, Machine, 5/8" x 14"	2 pieces
Bolt, Trimble Eye, 5/8" X 8", Angle Type	10 pieces
Bolt, Trimble Eye, 5/8" X 10", Angle Type	4 pieces
Bolt, Single Upsel, 5/8" x 8"	1 piece
Bracket, Angle, 5/8"	3 pieces
Bracket, Crossarm, 18" Drop 60" Span, Steel	9 each
Bracket, Mounting for Cutout and Arrestor	1 piece
Bracket, Mounting for Transformer Pole	2 pieces
Clamp, Hot Line, #2 - #2/0 ACSR Main to #2 - #2/0	6 pieces
Clamp, Anchor Rod Bonding, Single Eye	10 pieces
Clamp, Loop Deadend, #2/0 ACSR	4 pieces
Clamp, Deadend Strain, #1/0 ACSR	6 pieces
Clamp, Guy Straight, 3 Bolt, Heavy Duty Steel	20 pieces
Clamp, Deadend Grip, 3/8"	2 pieces
Clamp, Secondary Swinging without Spool	2 pieces
Conductor, 23 kv, Insulated, Three Core, Non Shielded HOPPELPEAWNG #1/0	1,020 meters
Conductor, Bare ACSR, #2 AWG (6/60/0)	340 meters
Conductor, Bare ACSR, #2 AWG (6/60/0)	340 meters
Conductor, Insulated Copper Wire, ACSR #2/0	15 meters
Conductor, Compression, YHD 150 #3, -#1/0 ACSR Run To #6 - #2	30 meters
Connector, Ground Rod (Clamp) for 5/8" Steel Rod	83 meters
Connector, Ground Rod (Clamp) for 5/8" Steel Rod	55 pieces
Fuse Cut-out & Arrestor Combination, 15kv, Class 200	2 pieces
Lightning Arrestor, 9-10 KV, Polymer	4 sets
Insulator, Pin Type, Porcelain, ANSI, Class 55 - 5	42 pieces
Insulator, Spool, 3", ANSI, Class 53 - 4	6 pieces
Pin, Crossarm, Steel, 1-3/8" x 14", 23KV	42 pieces
Insulator, Suspension, 6 Shed, Polymer, 15KV	6 pieces
Link, Fuse, Universal, Bottom Head, Type K, 15 Amperes	3 pieces
Link, Fuse, Universal, Bottom Head, Type K, 12 Amperes	3 pieces
Nut, Eye, 5/8", Conventional	8 pieces
Nut, Lock, M/T Type, 5/8"	116 pieces
Nut, Trimble Eye, 5/8"	4 pieces
Hook, Guy, 5/8"	8 pieces
Pin, Pole Top Channel, 1" Thread, 25" Long	7 pieces
Rod, Anchor, Threaded, Single Eye, 3/4" x 8"	7 pieces
Rod, Anchor, Threaded, Double Eye, 1" x 8"	8 pieces
Rod, Ground Steel, Galvanized, 5/8" x 10"	2 pieces
Transformer, Pole Type, Conventional, Silicon, 10 KVA	1 unit
Wire, Insulated, #2 AWG	72 meters
Washer, Square, 2-1/4" x 2-1/4" x 3/16" - 13/16" Diameter Hole	120 pieces
Wire, Steel, 1/2" Dia	120 meters
Wire, Guy, Steel, 3/8" 7 Strand	210 meters
Disconnecting Switch, 15 kv, 600A	3 units

PREPARED BY: 

RADNIE A. DUARTE

MANAGER, SYSTEM PLANNING & LINE CONSTRUCTION DIVISION

NOTED BY: 

ENGR RONALD D. ALOYAN

TSO MANAGER

APPROVED BY: 

ENGR. LEE D. RIVERA

GENERAL MANAGER



BANTAYAN ISLAND ELECTRIC COOPERATIVE, INC.
Baintawak, Bantigue, Bantayan, Cebu

BILL OF MATERIALS OF SUBMARINE CABLE RECEIVING POINT IN SITIO BAYABAS, BARANGAY, HILOTONGAN, BANTAYAN, CEBU

Single Phase Recloser, 400A	3 units
Pedestal Post	1 piece
Terminal Lug, #6, Single Hole	10 pieces
Terminal Lug, Long Barrel, #3/0, Single Hole	10 pieces
Terminal Lug, Long Barrel, #3/0, Double Hole	10 pieces
Stem Connector, Pigtail, #3/0	12 pieces
Cutout Cover (Source Side)	3 pieces
Cutout Cover (Load Side)	3 pieces
Transformer Bushing Cover	3 pieces
Lightning Arrestor Cover	10 pieces

Concrete/Steel Materials	
Pole, Steel, 35", Bare-3 mm, 88 Micron, 1000 kgs. (Minimum Load Break)	4 pieces
Pole, Steel, 40", Bare-4.0 mm, 88 Micron, 1280 kgs. (Minimum Load Break)	2 pieces
Block, Anchor, Concrete	10 pieces
Crossarm, Steel, 3" x 4" x 8", 3.0 mm	10 pieces
Crossarm, Steel, 3" x 4" x 10", 3.0 mm	16 pieces

Bill of Materials for Fencing

Gravel	20 cubic
Sand	30 cubic
Cement	50 sacks
Deform Bar, 9mm	54 pieces
Deform Bar, 10mm	20 pieces
Deform Bar, 12mm	54 pieces
G.I. Pipes, 2" dia., sch. 40	2 pieces
G.I. Pipes, 1 1/2" dia., sch. 40	2 pieces
Tie Wire, #16	50 kgs.
Steel Matting	2 pieces
Flat Bar, 1 1/2" X 20"	2 pieces
Concrete Primer & Sealer, White	10 gals.
Paint, Gloss Latex (Green)	10 gals.
Concrete Hollow Blocks, 4"	500 pieces

Equipment and Neutral Grounding Materials

Bare Copper, #2/0	12 meters
Grounding Copper Rod, 5/8" X 10'	7 pieces
Grounding Copper Wire, #4/0 AWG	64 meters
Grounding Copper Wire, #2 AWG	21 meters
Terminal Lug for #2/0 Insulated Copper Wire	12 pieces

Prepared by:

Radnie A. Duarte
Manager, SP-LC, Division

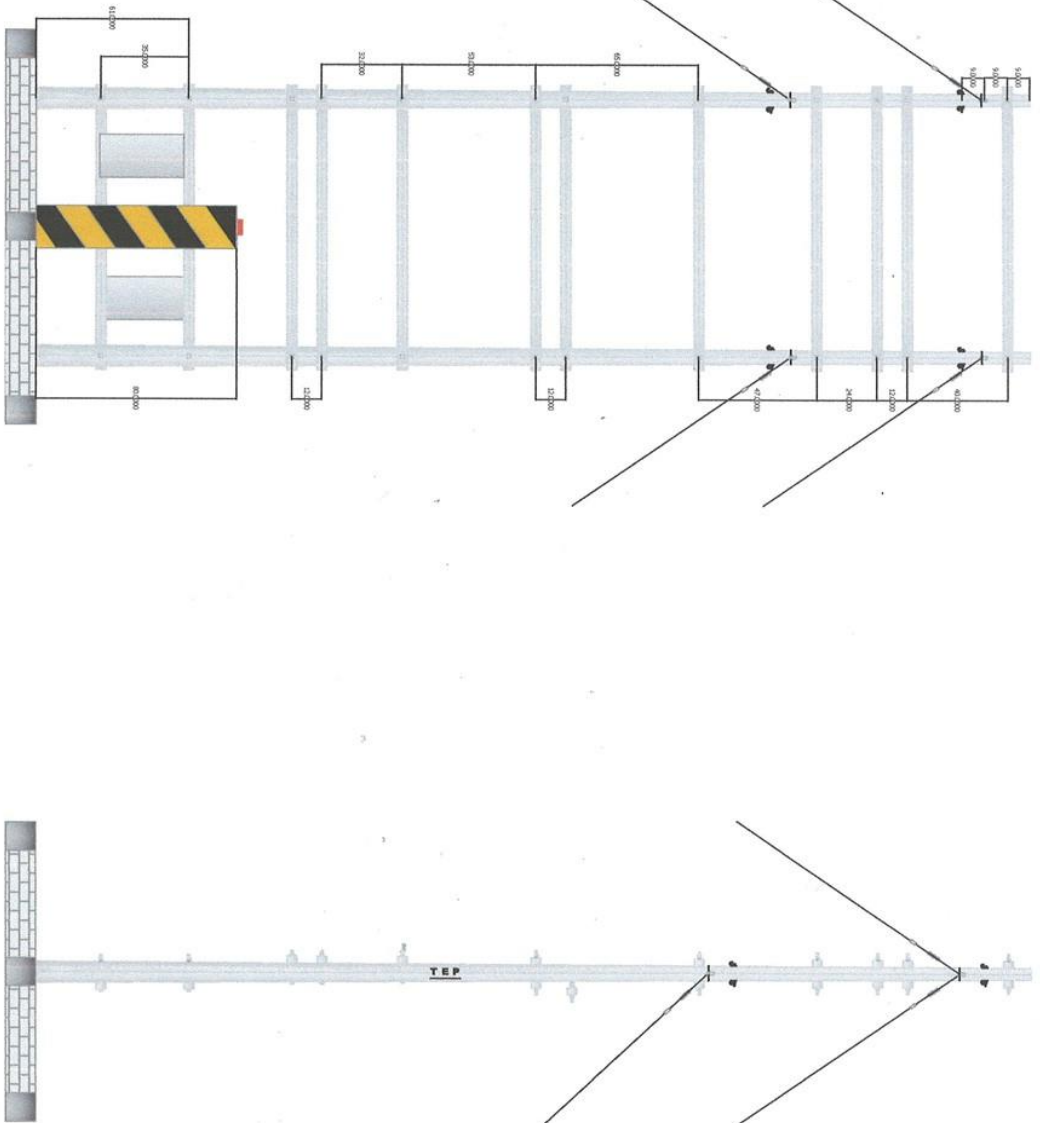

PREPARED BY:

 RADNIE A. DUARTE
 MANAGER, SYSTEM PLANNING & LINE CONSTRUCTION DIVISION

NOTED BY:

 ENGR RONALD D. ALRYAN
 TSD MANAGER

APPROVED BY:

 ENGR. LEE D. RIVERA
 GENERAL MANAGER

 BANTAYAN ISLAND ELECTRIC COOPERATIVE, INC.
 Balinhawak, Bantigue, Bantayan, Cebu
 PROPOSED FRAME STRUCTURE OF SUBMARINE CABLE RECEIVING POINT IN
 SITTO BAYABAS, BARANGAY, HILITONGSAN, BANTAYAN, CEBU

FRONT VIEW

SIDE VIEW

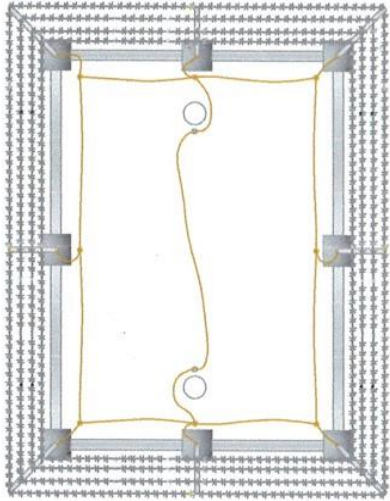

TOP VIEW

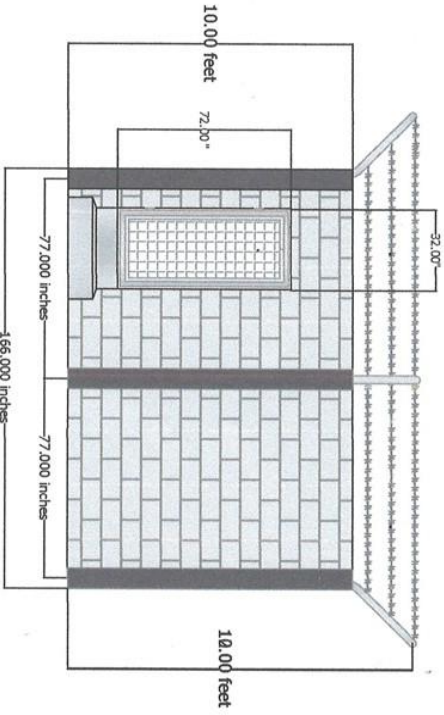
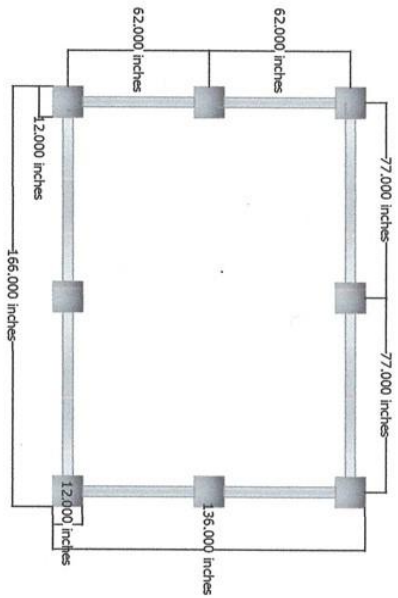

FRONT VIEW

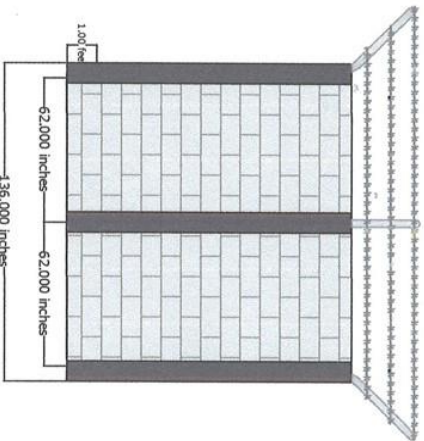

SIDE VIEW

PREPARED BY:
RADNIE A. DUARTE
RADNIE A. DUARTE
 MANAGER, SYSTEM PLANNING & LINE CONSTRUCTION DIVISION

NOTED BY:
ENG. RONALD D. ALBYAN
ENG. RONALD D. ALBYAN
 TSD MANAGER

APPROVED BY:
ENG. LEED. RIVERA
ENG. LEED. RIVERA
 GENERAL MANAGER

BANTAYAN ISLAND ELECTRIC COOPERATIVE, INC.
 Balintawak, Baridigue, Bantayan, Cebu
 PROPOSED H-FRAME STRUCTURE OF SUBMARINE CABLE RECEIVING POINT IN
 SITIO BAYABAS, BARANGAY, HILTONONGAN, BANTAYAN, CEBU

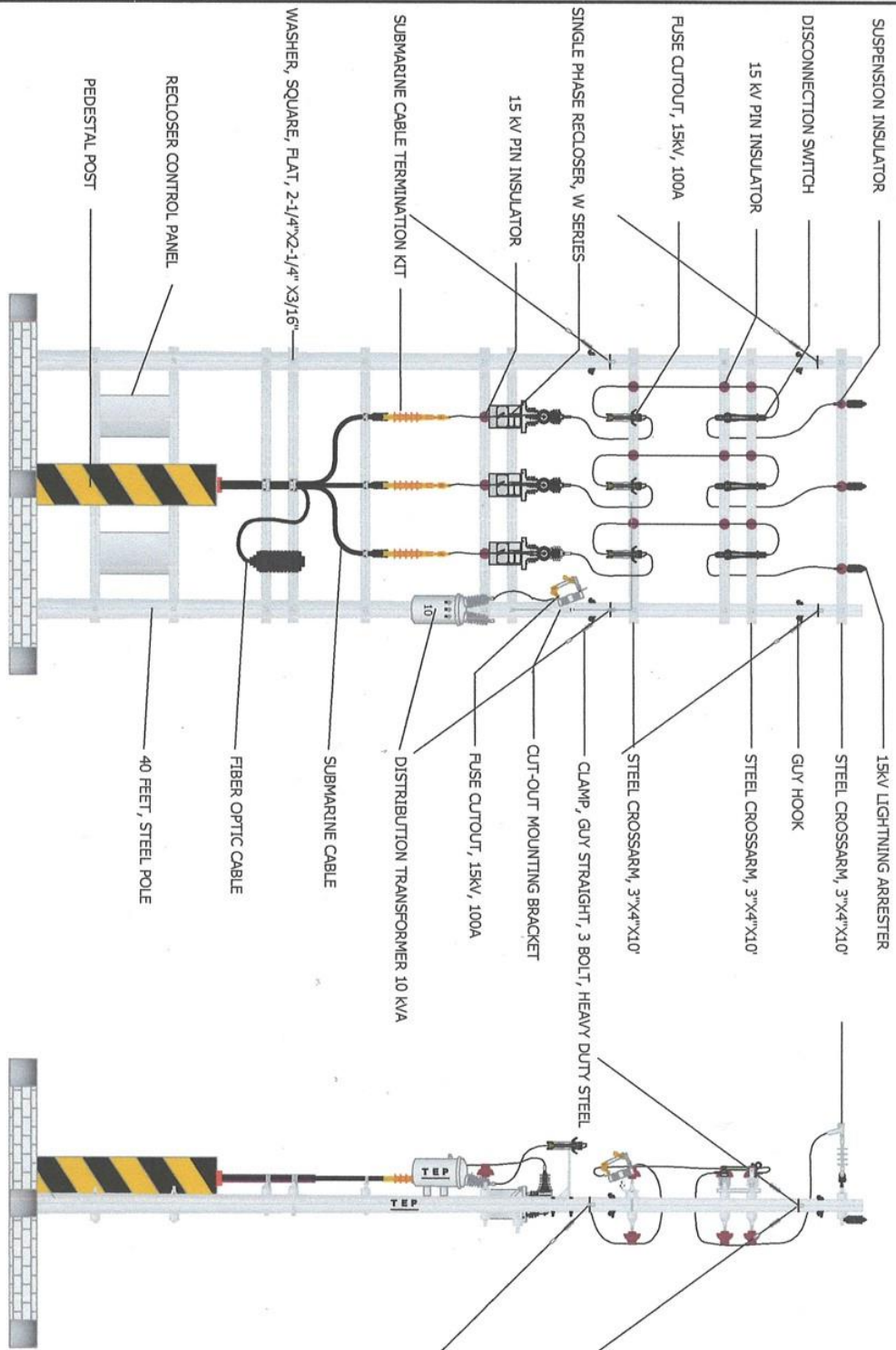

FRONT VIEW

SIDE VIEW

PREPARED BY: *R. Duarte*
RMONIE A. DUARTE
 MANAGER, SYSTEM PLANNING & LINE CONSTRUCTION DIVISION

NOTED BY: *R. Aloyan*
ENGR RONALD D. ALOYAN
 TSD MANAGER

APPROVED BY: *L. Rivera*
ENGR. LEE D. RIVERA
 GENERAL MANAGER

 **BANTAYAN ISLAND ELECTRIC COOPERATIVE, INC.**
 Balintawak, Bantigue, Bantayan, Cebu
 PROPOSED H-FRAME STRUCTURE OF SUBMARINE CABLE RECEIVING POINT IN
 SITIO BAYABAS, BARANGAY, HILOTONGAN, BANTAYAN, CEBU

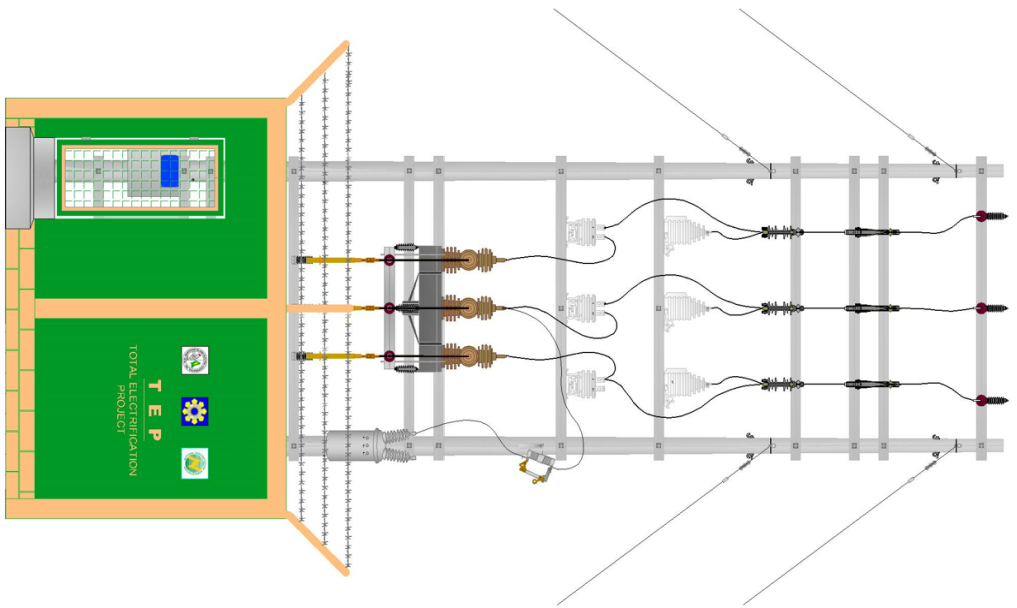

FRONT VIEW

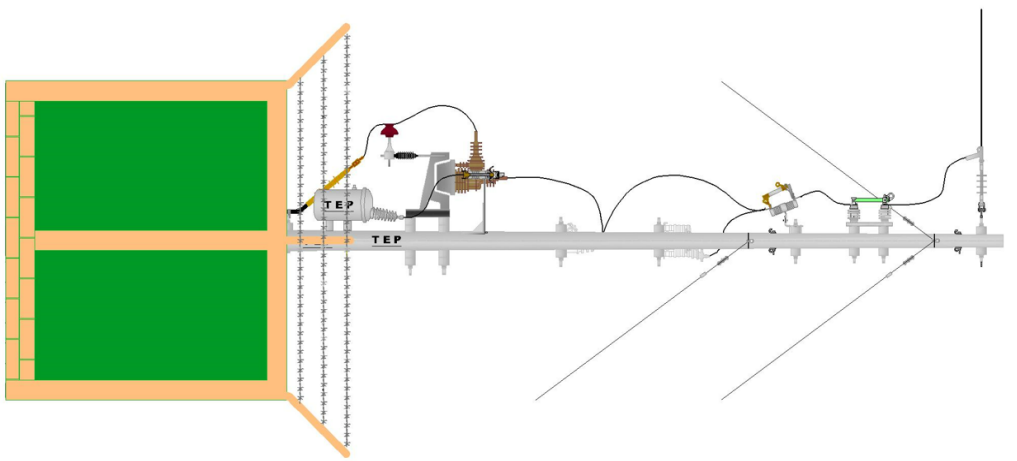

SIDE VIEW

PREPARED BY:

RAINIE A. DSARITE
 MANAGER, SYSTEM PLANNING & LINE CONSTRUCTION DIVISION

NOTED BY:

ENGR RONALD B. ALOYAN
 TSD MANAGER

APPROVED BY:

ENGR. LEE D. RIVERA
 GENERAL MANAGER

 **BANTAYAN ISLAND ELECTRIC COOPERATIVE, INC.**
 Balintawak, Bantigue, Bantayan, Cebu
 PROPOSED 4-FRAME STRUCTURE OF SUBMARINE CABLE SENDING POINT IN
 SITIO MOAMBOC, BARANGAY, SULANGAY, BANTAYAN, CEBU

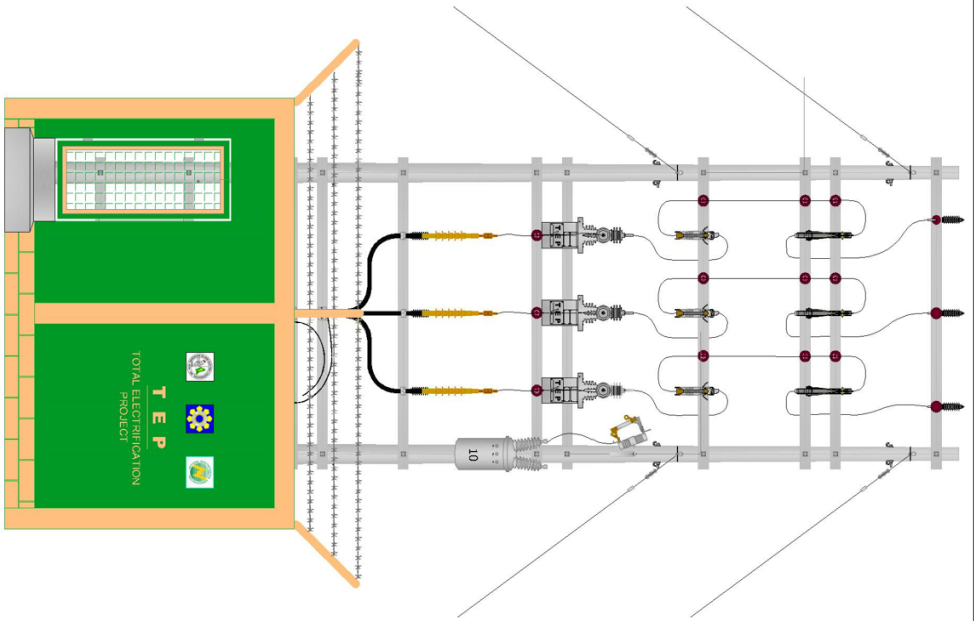

FRONT VIEW

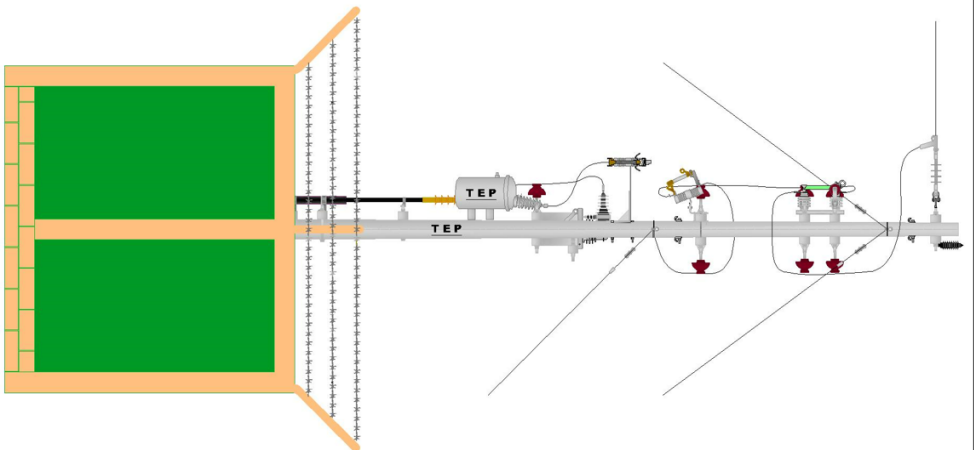

SIDE VIEW

PREPARED BY:

Radnie A. Duarte
RADNIE A. DUARTE

MANAGER, SYSTEM PLANNING & LINE CONSTRUCTION DIVISION

NOTED BY:

Eng'R. Ronald D. Aloyan
ENGR. RONALD D. ALOYAN
 TSD MANAGER

APPROVED BY:

Eng'R. Lee D. Rivera
ENGR. LEE D. RIVERA
 GENERAL MANAGER



BANTAYAN ISLAND ELECTRIC COOPERATIVE, INC.
 Baintawak, Bantigue, Bantayan, Cebu

PROPOSED H-RAME STRUCTURE OF SUBMARINE CABLE RECEIVING POINT IN
 SITIO BAYABAS, BARANGAY, HILOTONGAN, BANTAYAN, CEBU

S K E T C H



QUEZON CITY



STAKING SHEET (AS-PLANNED)

PROJECT NAME: TEP PROJECT

Checked By: _____ Staked By: _____

Date: 11/18/2024 9:57 P.M

SEE SHEET NO.

PRIMARY COND. #1/0 TREE WIRE
NEUTRAL COND. #1/0 6/1 AGRS
RUNNING SPAN 50 METERS

PROJECT NAME: BRGY. SULANGAN BANAYAN CEBU 3 PHASE PRIMARY LINE CONVERSION
SUBSTATION: 23 MW ISLA NORTE POWER CORPORATION (INPC)
LINE: 3 PHASE PRIMARY LINE IN SITIO MOAMBOC, SULANGAN, BANAYAN, CEBU
CONV. OF 2 SPAN OPEN SEC. LINE TO 3 PHASE & EXTN. OF 1 SPAN 3 PHASE PRIM. LINE TO SUBMARINE CABLE SENDING POINT IN SITIO MOAMBOC, SULANGAN, BANAYAN, CEBU

SHEET NO. 1 OF 1

Released By: _____ Final Inv. By: _____

PRI. BACK SPAN MTRS.

TRANS. FORMER "C"

GUY LEAD ANCH.

SEC. SEC. WIRE OR SIZE

SEC. SEC. "J"

SERVICE DROP WIRE

MISC. UNIT "M"

R/W -RI-

C O N S MEMBERS NAME AND NUMBER AND OR "REMARKS"

POLE NO. H.C. (A,B,C)

GRND. "W"

"E" M "F"

SPAN MTRS. UB

SEC. WIRE SIZE

SEC. SEC. "J"

DROP N I Z O

Q CODE Q CODE Q CODE

Q CODE Q CODE Q CODE

QTY C Q CODE Q CODE

Q CODE Q CODE Q CODE

Q CODE Q CODE Q CODE

QTY QTY QTY

Q CODE Q CODE Q CODE

Q CODE Q CODE Q CODE

Q CODE Q CODE Q CODE

Q CODE Q CODE Q CODE

Q CODE Q CODE Q CODE

TP EXISTING 1 C7-1

1 1-2 12 1 2-2

1 1-2 12 1 2-2

1 1-2 12 1 2-2

1 1-2 12 1 2-2

1 1-2 12 1 2-2

1 1-2 12 1 2-2

1 1-2 12 1 2-2

1 1-2 12 1 2-2

38 EXISTING 1 C2

1 1-2 12 1 2-2

1 1-2 12 1 2-2

1 1-2 12 1 2-2

1 1-2 12 1 2-2

1 1-2 12 1 2-2

1 1-2 12 1 2-2

1 1-2 12 1 2-2

1 1-2 12 1 2-2

45 EXISTING 1 C7-1

2 1-2 12 2 2-2

2 1-2 12 2 2-2

2 1-2 12 2 2-2

2 1-2 12 2 2-2

2 1-2 12 2 2-2

2 1-2 12 2 2-2

2 1-2 12 2 2-2

2 1-2 12 2 2-2

20 SUBMARINE CABLE SENDING POINT

EXISTING EXISTING EXISTING

EXISTING EXISTING EXISTING

EXISTING EXISTING EXISTING

EXISTING EXISTING EXISTING

EXISTING EXISTING EXISTING

EXISTING EXISTING EXISTING

EXISTING EXISTING EXISTING

EXISTING EXISTING EXISTING

329 TTTL

329 TTTL

329 TTTL

329 TTTL

329 TTTL

329 TTTL

329 TTTL

329 TTTL

329 TTTL

ATTACHED SKETCH PLAN

PREPARED BY:
RANIE A. DEARTE
Manager, SP-LC, Division

RECOMMENDED BY:
ENGR. RONALD D. ALOYAN
Manager, TSD Department

APPROVED BY:
ENGR. LEE D. RIVERA
General Manager



SITIO MOAMBOC
BRGY. SULANGAN

PREPARED BY:

 RADNIE A. DUARTE
 Manager, SP-L/C, Division

RECOMMENDED BY:

 ENGR. RONALD D. ALOYAN
 Manager, TSD Department

APPROVED BY:

 ENGR. LEE D. RIVERA
 General Manager

 BANTAYAN ISLAND ELECTRIC
 COOPERATIVE, INC.
 Balinawak, Bantayan, Bantayan, Cebu
 3 PHASE PRIMARY LINE CONVERSION TO SUBMARINE CABLE SENDING POINT
 IN SITIO MOAMBOC, SULANGAN, BANTAYAN, CEBU

S K E T C H (N)



NATIONAL ELECTRIFICATION ADMINISTRATION
QUEZON CITY

STAKING SHEET (AS-PLANNED)

PROJECT NAME: TEP PROJECT

Checked By: _____ Staked By: _____

Date: _____ Date: 11/19/2024 9:57 P.M

SEE SHEET NO. _____ PRIMARY COND. #1/0 TREE WIRE 6/1 ACRS SHEET NO. 1

NEUTRAL COND. #7/0 50 METERS RULING SPAN 50 SUBSTATION: NATIONAL POWER CORPORATION (NPC-SPUG) EXTENSION OF 5 SPAN 3 PHASE PRIMARY LINE TO SUBMARINE CABLE RECEIVING POINT IN SITIO BAYAAS, BRGY. HILITONGAN, BANTAVAN, CEBU

PROJECT NAME: BRGY. HILITONGAN BANTAVAN CEBU 3 PHASE PRIMARY LINE CONVERSION SHEET NO. 1 OF 1

Released By: _____ Final Inv. By: _____

POLE NO.	PRI. BACK SPAN MTRS.	POLE		PRIM. POLE UNIT (A,B,C)	LINE ANGLE	TRANS. FORMER "G"	GRND. "M"	GUY "E"	LEAD M	ANCH. "F"	SECONDARY		SEC. WIRE SIZE	SEC. "J"	DROPS MTRS. O	S I Z E	"K"	MISC. UNIT "M"	RW	C O N S	MEMBERS NAME AND NUMBER AND OR "REMARKS"	
		H	C								Q	Q										Q
TP		EXISTING	1	C7-1																		PRIMARY START.
1	60	1	35	SP 1																		
2	60	1	35	SP 1																		
3	60	1	35	SP 1																		
4	60	1	35	SP 1																		
5	60																					PRIMARY END @ H-FRAME OF RECEIVING POINT.
QUANTITY	C	Q	Q	Q	Q	Q	Q	Q	Q	Q	Q	Q	Q	Q	Q	Q	Q	Q	Q	Q	Q	Q
100	4	35	SP 1																			
26				3	C2	G9-26																
300	36			1	C1	G9-1	M2-11A 4	E3-2														
900	TTL																					

SEE SHEET NO. _____

PREPARED BY: R. A. DYARTE
Manager, SP-LC, Division

RECOMMENDED BY: E. D. ALOYAN
ENGR. RONALD D. ALOYAN
Manager, TSD Department

APPROVED BY: E. D. RIVERA
General Manager

SITIO BAYABAS DOS BRGY. HILOTONGAN

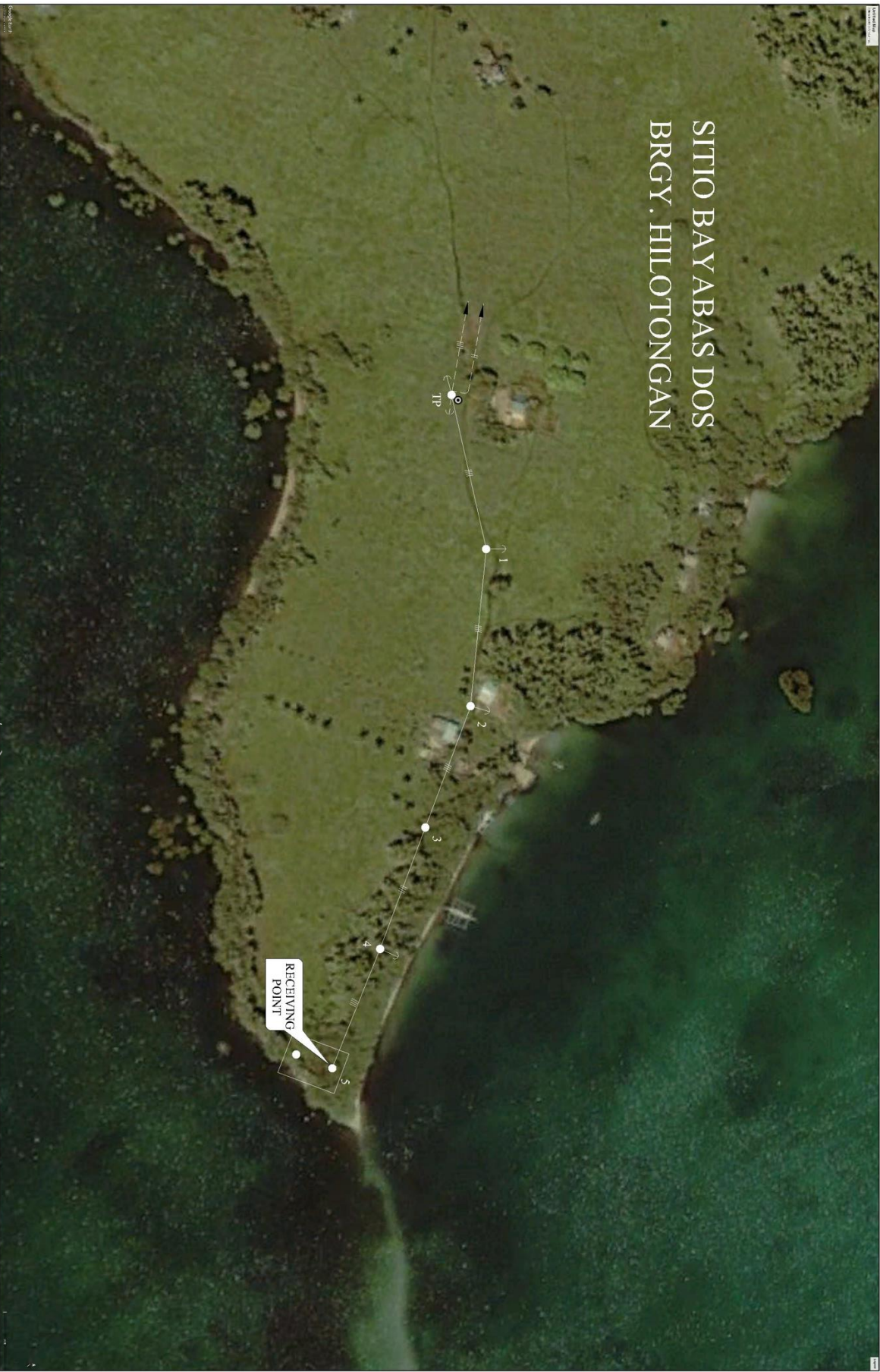

PREPARED BY:

KADNIE A. DUARTE
 Manager, SP-LC, Division

RECOMMENDING APPROVAL BY:

ENGR. RONALD D. ALOYAN
 Manager, TSD Department

APPROVED BY:

ENGR. LEE D. RIVERA
 General Manager

BANTAYAN ISLAND ELECTRIC COOPERATIVE, INC.
 Balinhawak, Bantigue, Bantayan, Cebu
3 PHASE PRIMARY LINE EXTENSION TO SUBMARINE CABLE RECEIVING POINT IN SITIO BAYABAS DOS, HILOTONGAN, BANTAYAN, CEBU

Section VII. Scope of Work

SCOPE OF WORK

1. Specific

Scope of work shall include Supply Delivery and Installation of Supply, Delivery and Installation of On-shore Cable Protection, Primary Metering, Line Conversion and Extension and Termination of SUBMARINE CABLE and Fiber Optics under the Supervision of winning Bidder of Lot 1 in Moamboc, Sulangan and Hilotongan, Bantayan, Cebu to meet the requirement defined in specifications, data sheets and drawings attached with the tender and required for completion of the job within 60 calendar days upon signing of contract..

2. Winning Bidder shall provide the ff:

2.1) Program of Work & Field quality assurance plan with time schedule for each activity.

3. Protections & Primary Metering

3.1 Installation of Three Phase Primary Metering & Protections such as Recloser (3 Phase unit) & Main Disconnect Switches at Sending Point.

3.2 Installation of 3 units single Phase Reclosers, Cut-outs & Main Disconnect Switches at Receiving Point.

3.3 Perimeter Fencing of both sending and receiving points.

4. Construction of Distribution Lines for Tapping Points of Sending and Receiving Points.

4.1 Three spans Line Upgrading from Single Phase to Three Phase at Moamboc Islet.

4.2 Five Spans 3-Phase Line Extension at Hilotongan Islet.

5. Acceptance

5.1) The winning bidder shall provide the BANELCO with the following:

5.1.1) Certificate of Completion with the following attachments:

a) As Built Layout (Scaled) duly signed by Professional Electrical Engineer

b.) As Built Materials with Specifications duly signed by Professional Electrical Engineer

5.1.2) Original Permits and Clearances.

5.1.3) Certificate of Energization duly signed Barangay Captain.

5.1.4) Warranty Certificate duly notarized.

5.1.5) Documentations including video compilations and images during the project implementation.

5.2) Installation of Warning Signs at Receiving and Sending Points such as;

5.2.1) Danger No Anchoring

5.2.2) Danger High Voltage, etc.

6. The following tests shall be carried out after installation in accordance with

IEC60502-2, ITU-T G.652

a) A.C soak test (on the cables after installation) AC 8.7kv for 24 hrs.

The commissioning test for this project will be 24-hours trial test on actual transmission line.

b) Attenuation test (on completed cable); Max 0.4 dB/km @ 1310nm

BANELCO has no responsibility on any damages or losses during the conduct of testing and commissioning duly witnessed by BANELCO & NEA Representative on Site Test.

NOTE: CHANGES IN SCOPE OF WORK. BANELCO shall be free to alter, add to or delete any part of the job without any compensation to the contractor, in case the contractor fails to provide sufficient labor / materials under his scope for the execution and completion of the work on schedule as per BANELCO's assessment.

Section VII. Bidding Forms

Form#1: Confirming Statement on Project Duration

(Letterhead of the Bidder)

Date: _____, 2024

Attention: Engr. Ronald D. Aloyan
BANELCO BAC Chairman

Confirming Statement on Project Duration

Lot Number	Description	Project Completion	Bidders Statement *
3	Supply, Delivery and Installation of On-shore Cable Protection, Primary Metering, Line Conversion and Extension	60 CD	

I hereby certify to comply the above requirements.

Name of Company/Bidder

Signature Over Printed Name of Authorized Representative

*statement of comply or equivalent term will suffice.

Form#2: Confirming Statement on Warranty and Defects Liability Period

(Letterhead of the Bidder)

Date: _____, 2024

The BAC Chairman
BANELCO
Bantigue, Bantayan, Cebu

Attention: Engr. Ronald D. Aloyan
BANELCO BAC Chairman

Subject: Confirming Statement on Warranty and Defects Liability Period

[Name of Bidder] hereby unconditionally declares that:

1. It shall cover the warranty for On-shore Cable Protections, Primary Metering, Line Conversion and Extension for a minimum of **One (1) Year** counted from the time that the Submarine Cable Project Completion and Acceptance was issued by BANELCO.
3. The warranty in favor of BANELCO shall survive even after the expiration of the Contract.
4. It understands and shall abide by the Warranty provisions as provided in the Bidding Documents.

(Name of Bidder)

By: [Signature]

[Name of Authorized Representative]

[Position/Designation]

Form#3: Details of Construction Equipment

(Letterhead of the Bidder)

Date: _____, 2024

The BAC Chairman
BANELCO
Bantigue, Bantayan, Cebu

Attention: Engr. Ronald D. Aloyan
BANELCO BAC Chairman

Subject: **Details of Construction Equipment**

[Name of Bidder] hereby unconditionally declares that:

Below is the list of minimum requirements for the installation/laying of Submarine Cable:

BANELCO'S MINIMUM CONSTRUCTION EQUIPMENT REQUIREMENTS				Bidders Remarks (Owned/Lease)
1	Boom truck	1	Unit	
2	Work/Service boats	1	Unit	
3	Jackhammers	2	Units	
4	Concrete Mixer	1	Unit	

[Name of Bidder]

By: [Signature]

[Name of Authorized Representative]

[Position/Designation]

Form#4: Bid Prices in Bill of Quantities

Bid Form

Date: _____

BANELCO ITB No.: 2024-004

The BAC Chairman
BANELCO
Bantigue, Bantayan, Cebu

Gentlemen and Ladies:

Having examined the Bidding Documents including Bid Bulletin Number [____], the receipt of which is hereby duly acknowledge, we, the undersigned, offer to Supply for labor for Supply, Delivery and Installation of On-shore Cable Protection, Primary Metering, Line Conversion and Extension in Moamboc, Sulangan and Hilotongan, Bantayan, Cebu (Lot 3) within 60 calendar days upon signing of contract;

No.	DESCRIPTION	Qty	Unit	Rate	Amount
1	Land Engineering Works				
	- Civil Works /Fencing of Sending & Receiving Points	1	lot		
2	On-shore Cable Protection & Primary Metering				
	- Dry Mix Concrete	1	lot		
	- Installation of Reclosers at Sending & Receiving Points	1	lot		
	- Installation of Disconnect Switches, Accessories	1	lot		
	- Installation of Primary Metering at Sending Point	1	lot		
3	Testing of Cable, Termination and splicing of termination kit and its accessories (Sending and Receiving End)	1	lot		
4	Line Upgrading and Extension at Moamboc and Hilotongan Islets Bantayan Cebu.	1	lot		
Total Project Cost Php					

UNIT IN WORDS: _____

We undertake, if our Bid is accepted, to supply for labor in accordance with the work schedule specified in the Schedule of Requirements/Project Duration.

If our Bid is accepted, we undertake to provide a performance security in the form, amounts, and within the times specified in the Bidding Documents.

We agree to abide by this Bid for the Bid Validity Period specified in **BDS** provision for **ITB** Clause 15.2 and it shall remain binding upon us and may be accepted at any time before the expiration of that period.

Until a formal Contract is prepared and executed, this Bid, together with your written acceptance thereof and you're Notice of Award, shall be binding upon us.

We understand that you are not bound to accept the lowest or any Bid you may receive.

We certify/confirm that we comply with the eligibility requirements as per specified Section IX of the Bidding Documents

Dated this _____ day of _____ 20_____.

[signature]

[in the capacity of]

Duly authorized to sign Bid for and on behalf of

Omnibus Sworn Statement

REPUBLIC OF THE PHILIPPINES) CITY/MUNICIPALITY
OF _____) S.S.

AFFIDAVIT

I, *[Name of Affiant]*, of legal age, *[Civil Status]*, *[Nationality]*, and residing at *[Address of Affiant]*, after having been duly sworn in accordance with law, do hereby depose and state that:

1. ***Select one, delete the other:***

If a sole proprietorship: I am the sole proprietor or authorized representative of *[Name of Bidder]* with office address at *[address of Bidder]*;

If a partnership, corporation, cooperative, or joint venture: I am the duly authorized and designated representative of *[Name of Bidder]* with office address at *[address of Bidder]*;

2. ***Select one, delete the other:***

If a sole proprietorship: As the owner and sole proprietor or authorized representative of *[Name of Bidder]*, I have full power and authority to do, execute and perform any and all acts necessary to participate, submit the bid, and to sign and execute the ensuing contract for *[Name of the Project]* of the *[Name of the Procuring Entity]* *[insert "as shown in the attached duly notarized Special Power of Attorney" for the authorized representative]*;

If a partnership, corporation, cooperative, or joint venture: I am granted full power and authority to do, execute and perform any and all acts necessary to participate, submit the bid, and to sign and execute the ensuing contract for *[Name of the Project]* of the *[Name of the Procuring Entity]*, accompanied by the duly notarized Special Power of Attorney, Board/Partnership Resolution, or Secretary's Certificate, whichever is applicable;

3. *[Name of Bidder]* is not "blacklisted" or barred from bidding by the Government of the Philippines or any of its agencies, offices, corporations, or Local Government Units, foreign government/foreign or international financing institution whose blacklisting rules have been recognized by the Government Procurement Policy Board;

4. Each of the documents submitted in satisfaction of the bidding requirements is an authentic copy of the original, complete, and all statements and information provided therein are true and correct;

5. *[Name of Bidder]* is authorizing the Head of the Procuring Entity or its duly authorized representative(s) to verify all the documents submitted;

6. ***Select one, delete the rest:***

If a sole proprietorship: The owner or sole proprietor is not related to the Head of the Procuring Entity, members of the Bids and Awards Committee (BAC), the Technical Working Group, and the BAC Secretariat, the head of the Project Management Office or the end-user unit, and the project consultants by consanguinity or affinity up to the third civil degree;

If a partnership or cooperative: None of the officers and members of *[Name of Bidder]* is related to the Head of the Procuring Entity, members of the Bids and Awards Committee (BAC), the Technical Working Group, and the BAC Secretariat, the head of the Project Management Office or the end-user unit, and the project consultants by consanguinity or affinity up to the third civil degree;

If a corporation or joint venture: None of the officers, directors, and controlling stockholders of *[Name of Bidder]* is related to the Head of the Procuring Entity, members of the Bids and Awards Committee (BAC), the Technical Working Group, and the BAC Secretariat, the head of the Project Management Office or the end-user unit, and the project consultants by consanguinity or affinity up to the third civil degree;

7. *[Name of Bidder]* complies with existing labor laws and standards; and

8. *[Name of Bidder]* is aware of and has undertaken the following responsibilities as a Bidder:

a) Carefully examine all of the Bidding Documents;

b) Acknowledge all conditions, local or otherwise, affecting the implementation of the Contract;

c) Made an estimate of the facilities available and needed for the contract to be bid, if any; and

d) Inquire or secure Supplemental/Bid Bulletin(s) issued for the *[Name of the Project]*.

9. *[Name of Bidder]* did not give or pay directly or indirectly, any commission, amount, fee, or any form of consideration, pecuniary or otherwise, to any person or

official, personnel or representative of the government in relation to any procurement project or activity.

IN WITNESS WHEREOF, I have hereunto set my hand this ___ day of ___, 20__ at _____, Philippines.

Bidder's Representative/Authorized Signatory

SUBSCRIBED AND SWORN to before me this ___ day of [month] [year] at [place of execution], Philippines. Affiant/s is/are personally known to me and was/were identified by me through competent evidence of identity as defined in the 2004 Rules on Notarial Practice (A.M. No. 02-8-13-SC). Affiant/s exhibited to me his/her [insert type of government identification card used], with his/her photograph and signature appearing thereon, with no. _____ and his/her Community Tax Certificate No. _____ issued on ___ at _____.

Witness my hand and seal this ___ day of [month] [year].

NAME OF NOTARY PUBLIC

Serial No. of Commission _____

Notary Public for _____ until _____

Roll of Attorneys No. _____

PTR No. _____ [date issued], [place issued]

IBP No. _____ [date issued], [place issued]

Doc. No. _____

Page No. _____

Book No. _____

Series of _____

Form#6: The Statement of the Bidder's Single Largest Completed Contract (SLCC) similar to the contract to be bid

(Letterhead of the Bidder)

Date: _____, 2024

The BAC Chairman
 BANELCO
 Bantigue, Bantayan, Cebu

Attention: Engr. Ronald D. Aloyan
 BANELCO BAC Chairman

Subject: The Statement of the Bidder's Single Largest Completed Contract (SLCC) similar to the contract to be bid

[Name of Bidder] hereby unconditionally declares that:

Business Name:

Business Adress:

Name of Contract (s)	a. Owner's Name	Nature of Work	Contract Role		a. Amount at Award	a. Date Awarded
	b. Address		Description	%	b. Amount at Completion	b. Contract Effectivity
	c. Telephone No.s				c. Duration	c. Date Completed

Submitted by: _____

Signature: _____

Designation: _____

Date: _____

Form#7: Statement of All Completed and On-going Government and Private Contracts Including Awarded but Not Yet Started

(Letterhead of the Bidder)

Date: _____, 2024

The BAC Chairman
 BANELCO
 Bantigue, Bantayan, Cebu

Attention: Engr. Ronald D. Aloyan
 BANELCO BAC Chairman

Subject: Statement of All Completed and On-going Government and Private Contracts Including Awarded but Not Yet Started

[Name of Bidder] hereby unconditionally declares that:

Business Name:

Business Address:

Name of Contract/Location/ Project Cost	a. Owner's Name	Nature of Work	Contract Role		a. Date Awarded	Value of Outstanding Works
	b. Address		Description	%	b. Date Started	
	c. Telephone No.s				c. Date Completed	
					d. Estimated Completion Time	
					Total Cost	

Submitted by: _____

Signature: _____

Designation: _____

Date: _____

Form of Contract Agreement

THIS AGREEMENT, made this *[insert date]* day of *[insert month]*, *[insert year]* between *[name and address of PROCURING ENTITY]*_(hereinafter called the“Entity”) and *[name and address of Contractor]* (hereinafter called the “Contractor”).

WHEREAS, the Entity is desirous that the Contractor execute *[name and identification number of contract]* (hereinafter called “the Works”) and the Entity has accepted the Bid for *[insert the amount in specified currency in numbers and words]* by the Contractor for the execution and completion of such Works and the remedying of any defects therein.

NOW THIS AGREEMENT WITNESSETH AS FOLLOWS:

1. In this Agreement, words and expressions shall have the same meanings as are respectively assigned to them in the Conditions of Contract hereinafter referred to.
2. The following documents shall be attached, deemed to form, and be read and construed as part of this Agreement, to wit:
 - (a) General and Special Conditions of Contract;
 - (b) Drawings/Plans;
 - (c) Specifications;
 - (d) Invitation to Apply for Eligibility and to Bid;
 - (e) Instructions to Bidders;
 - (f) Bid Data Sheet;
 - (g) Addenda and/or Supplemental/Bid Bulletins, if any;
 - (h) Bid form, including all the documents/statements contained in the Bidder’s bidding envelopes, as annexes;
 - (i) Eligibility requirements, documents and/or statements;
 - (j) Performance Security;
 - (k) Credit line issued by a licensed bank, if any;
 - (l) Notice of Award of Contract and the Bidder’s conforme thereto;
 - (m) Other contract documents that may be required by existing laws and/or the Entity.
3. In consideration of the payments to be made by the Entity to the Contractor as hereinafter mentioned, the Contractor hereby covenants with the Entity to execute and complete the Works and remedy any defects therein in conformity with the provisions of this Contract in all respects.

4. The Entity hereby covenants to pay the Contractor in consideration of the execution and completion of the Works and the remedying of defects wherein the Contract Price or such other sum as may become payable under the provisions of this Contract at the times and in the manner prescribed by this Contract.

IN WITNESS whereof the parties thereto have caused this Agreement to be executed the day and year first before written.

Signed, sealed, delivered by _____ the _____ (for the Entity)

Signed, sealed, delivered by _____ the _____ (for the Contractor).

Binding Signature of PROCURING ENTITY

Binding Signature of Contractor

[Addendum showing the corrections, if any, made during the Bid evaluation should be attached with this agreement]

Section IX. Checklist of Technical and Financial Documents

Checklist of Technical and Financial Documents

I. TECHNICAL COMPONENT ENVELOPE

Folder 1 Legal Documents/ Class “A” Documents

- (a) Registration Certificate issued by the Securities and Exchange Commission (SEC) for Partnerships and Corporations; by the Department of Trade and Industry (DTI) for sole proprietorships; or by the Cooperative Development Authority (CDA) for cooperatives;
- (b) Valid and current Mayor’s/Business permit issued by the city or municipality where the principal place of business of the prospective bidder is located or equivalent document;

A recently expired Mayor’s/Business permit together with the official receipt as proof that the prospective bidder has applied for renewal within the period prescribed by the concerned local government unit, shall be accepted. However, the valid and current Mayor’s/Business permit must be provided during the post qualification stage.

- (c) Tax Clearance from the Bureau of Internal Revenue (BIR) to prove bidder’s full and timely payment of taxes to the Government;
- (d) BIR Value Added Tax Registration;
- (e) Proofs of VAT payment for the last six (6) months (May 2024- October 2024) preceding the bid opening date;
- (f) Original duly signed Omnibus Sworn Statement (OSS) **and** if applicable, Original Notarized Secretary’s Certificate in case of a corporation, partnership, or cooperative; or Original Special Power of Attorney of all members of the joint venture giving full power and authority to its officer to sign the OSS and do acts to represent the Bidder (**See Bidding Form#5**).

Folder 2 Technical Documents

- (a) Statement of the prospective bidder of all its ongoing government and private contracts, including contracts awarded but not yet started, if any, whether similar or not similar in nature and complexity to the contract to be bid; **See Bidding Form #7**

- (b) Bidder’s Statement of Single Largest Completed Contract (SLCC) that is similar to the Project (*Supply and Delivery of Submarine Power Cable*) completed for the last ten years. The SLCC: (a) must be equivalent to Fifty Percent (50%) of the Total ABC. **See Bidding Form #6**. This is also supported by The Owner’s Certificate of Final

Acceptance; or the Constructors Performance Evaluation Summary (CPES) Final Rating and/or the Certificate of Completion, must be **Satisfactory**.

(c) A valid Electrical PCAB License or Offshore Engineering or special PCAB License in case of Joint Ventures, and registration for the type and cost of the contract for this Project.

(d) Project Requirements, which shall include the following:

- a. Organizational chart for the contract to be bid;
- b. List of contractor's key personnel (*e.g.*, Project Manager, Project Engineers, Materials Engineers, and Foremen), to be assigned to the contract to be bid, with their complete qualification and experience data;
- c. List of contractor's major equipment units, which are owned, leased, and/or under purchase agreements, supported by proof of ownership or certification of availability of equipment from the equipment lessor/vendor for the duration of the project, as the case may be.

Folder 3 Financial Documents

(a) Complete set of audited financial statements, stamped "received" by the BIR or its duly accredited and authorized institutions, for the preceding calendar year, which should not be earlier than two (2) years from the date of bid submission;

Complete set of financial statement includes the following:

- i. Balance Sheet;
- ii. Income Statement;
- iii. Statement of Changes in Equity;
- iv. Cash Flow Statement;
- v. Notes to Financial Statement; and
- vi. Statement of Management Responsibility for Financial Statement.

(b) The Bidder must submit a computation of its Net Financial Contracting Capacity (NFCC), which must be at least equal to the ABC to be bid, calculated as follows:

$$\text{NFCC} = [(\text{Current assets minus current liabilities}) (15)] \text{ minus the value of all outstanding or uncompleted portions of the projects under ongoing contracts, including awarded contracts yet to be started coinciding with the contract for this Project.}$$

The values of the domestic bidder's current assets and current liabilities shall be based on the latest Audited Financial Statements (AFS) submitted to the BIR.

For purposes of computing the foreign bidders' NFCC, the value of the current assets and current liabilities shall be based on their audited financial statements prepared in accordance with international financial reporting standards.

Folder 4 Class "B" Documents

In case of a Joint venture:

- (a) Valid Joint Venture Agreement (JVA), in case the Joint Venture is in existence. The JVA should contain provisions which clearly reflect the following matters: (a) the respective contributions of the JV Partners; (b) the respective responsibilities/roles of the JV Partners; and (c) the valuation of each of the JV Partners' respective contributions; or
- (b) In the absence of a JVA, duly notarized statements from all the potential joint venture partners which shall include statements that: (a) they will enter into and abide by the provisions of the JVA in the event that the bid is successful; and (b) failure to enter into a JVA in the event of a contract award shall be a ground for bid disqualification and subsequent forfeiture of the bid security.

Each partner of the joint venture shall submit their respective legal eligibility requirements. The submission of the technical and financial eligibility requirement by any of the joint venture partners constitutes compliance. Provided, that the partner responsible to submit the NFCC shall likewise submit the Statement of all of its ongoing contracts and Audited Financial Statements.

Folder 5 Bid Securities in the prescribed form, amount and validity period

- (a) Bid securities (valid for 120 calendar days from the date of the opening of bids) payable to BANELCO in the following forms and amounts;

Form of Bid Security	Amount of Bid Security (Equal to Percentage of the ABC)
(a) Cash or cashier's/manager's check issued by a Universal or Commercial Bank.	Two percent (2%)
(b) Bank draft/guarantee or irrevocable letter of credit issued by a Universal or Commercial Bank: Provided, however, that it shall be confirmed or authenticated by a Universal or Commercial Bank, if issued by a foreign bank.	
(c) Surety bond callable upon demand issued by a surety or insurance company duly certified by the Insurance Commission as authorized to issue such security.	Five percent (5%)

II. FINANCIAL COMPONENT ENVELOPE 2

Folder 1 Technical Proposal

- (a) Confirming Statement on Project Duration (See Bidding Form#1);
- (b) Confirming Statement on warranty (See Bidding Form#2); and
- (c) Details of Construction Equipment (See Bidding Form#3).

Folder 2 Financial Proposal

- (a). Original of duly signed Bid Prices in the Bill of Quantities (See Bidding Form#4)
- (b). Duly accomplished Detailed Estimates Form, including a summary sheet indicating the unit prices of construction materials, labor rates, and equipment rentals used in coming up with the Bid.

(END)

